



# SERVICE DIVISION

## DEALER TRAINING

**AID #** S1029

**SUBJECT:** BORG-WARNER MODEL 65 PRINCIPLES, REBUILD, MAINTENANCE  
AND DIAGNOSIS

**MODEL:** TRIUMPH TR7 AND JAGUAR XJ6

AUSTIN

JAGUAR

MG

LAND ROVER

TRIUMPH

I N D E X

	<u>PAGE</u>
PREFACE . . . . .	1
GENERAL INTRODUCTION . . . . .	1
TORQUE CONVERTOR . . . . .	2
CLUTCH AND BAND APPLICATION IN VARIOUS GEAR POSITIONS . . . . .	3
MECHANICAL POWER FLOW . . . . .	4
Neutral and Park . . . . .	4
First Gear 'D' Selected . . . . .	4
First Gear '1' Selected . . . . .	5
Second Gear 'D', '2' or '1' Selected . . . . .	5
Third Gear 'D' Selected . . . . .	6
Reverse Gear 'R' Selected . . . . .	6
TRANSMISSION ASSEMBLY . . . . .	7
Dismantle Transmission . . . . .	7
Planet Carrier . . . . .	17
One-Way Clutch . . . . .	18
Primary Sun Gear Shaft . . . . .	19
Rear Clutch . . . . .	19
Front Clutch . . . . .	25
Oil Pump . . . . .	32
Front Servo . . . . .	33
Rear Servo . . . . .	34
Governor . . . . .	35
Brake Bands . . . . .	36
Output Shaft and Ring Gear . . . . .	36
Gear Case . . . . .	38
Transmission Assembly . . . . .	39
VALVE BODY . . . . .	49
Valve Body Service . . . . .	49
HYDRAULIC SYSTEM - VALVE OPERATION AND FUNCTION . . . . .	55
Primary Regulator Valve . . . . .	55
Secondary Regulator Valve . . . . .	55
Downshift Valve and Throttle Valve . . . . .	55
Shift Control Valves . . . . .	55



I N D E X (Cont.)

	<u>PAGE</u>
Manual Control Valve . . . . .	55
Servo Orifice Control Valve . . . . .	56
Modulator Plug and Valve . . . . .	56
Governor Versus Throttle Pressure . . . . .	56
Neutral . . . . .	57
Park . . . . .	58
Drive 'D' (First Gear) . . . . .	59
Drive 'D' (Second Gear) . . . . .	60
Drive 'D' (Third Gear) . . . . .	61
'2' (Low Gear) . . . . .	62
'2' (Second Gear) . . . . .	63
'1' (Low Gear) . . . . .	64
'1' (Second Gear) . . . . .	65
'R' (Reverse) . . . . .	66
 MAINTENANCE AND ADJUSTMENT PROCEDURE . . . . .	 67
Checking Fluid Level . . . . .	67
The Downshift Valve Cable . . . . .	67
Downshift Cable Adjustment . . . . .	68
Manual Shift Rod . . . . .	70
Gear Selector Cable Adjustment . . . . .	70
The Inhibitor Switch - (Neutral Safety Switch) . . . . .	71
Starter Inhibitor Switch - Check and Adjust . . . . .	71
The Brake Bands . . . . .	73
Stall Pressure Test . . . . .	73
 ROAD TEST PROCEDURES . . . . .	 74
 FAULT DIAGNOSIS . . . . .	 75
 TRANSMISSION FAULT KEY . . . . .	 77
 GEAR CHANGE SPEEDS . . . . .	 78

Provided Courtesy of Triumph Wedge Owners Association  
<http://www.triumphwedgeowners.org>

## P R E F A C E

The information contained in this booklet is provided as an easy reference guide for technicians. More detailed information is available in the appropriate Workshop Manual.

## GENERAL INTRODUCTION

The model 65 transmission is a 3-speed automatic consisting of a torque convertor, planetary gear set, two hydraulic clutches, two servos and brake bands and a valve body assembly.

© Copyright British Leyland Motors Inc. - 1976



### TORQUE CONVERTOR

The torque convertor is nothing more than a means of transferring power from the engine to transmission and is, in effect, an automatic clutch. It comprises three main elements: impeller (pump), stator mounted on a one-way clutch and turbine.

The impeller, driven by the engine, picks up oil and throws it to the turbine which drives the transmission. The stator is mounted in between the impeller and turbine on a one-way clutch. The stator's function is to redirect the oil coming from the turbine so that it reenters the impeller in the same direction as the impeller is rotating until 'lock up' is achieved at which time the stator freeheels on the one-way clutch.

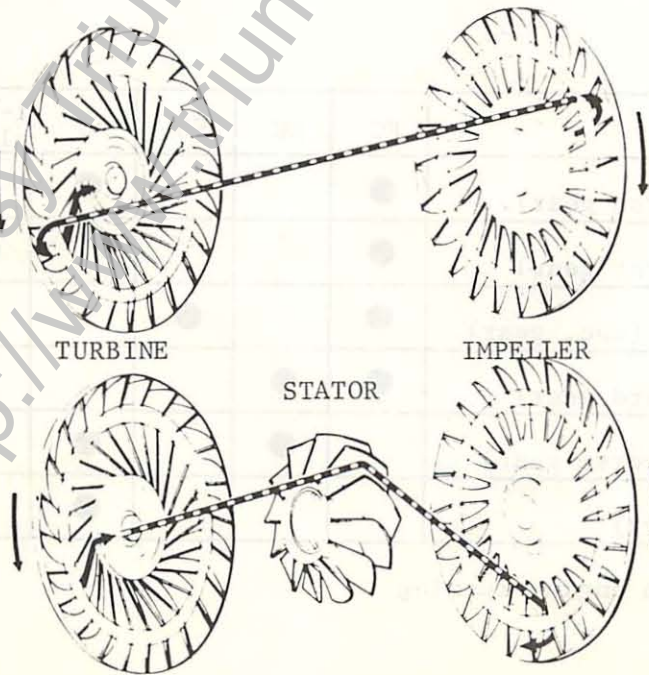

CLUTCH AND BAND APPLICATION IN VARIOUS GEAR POSITIONS

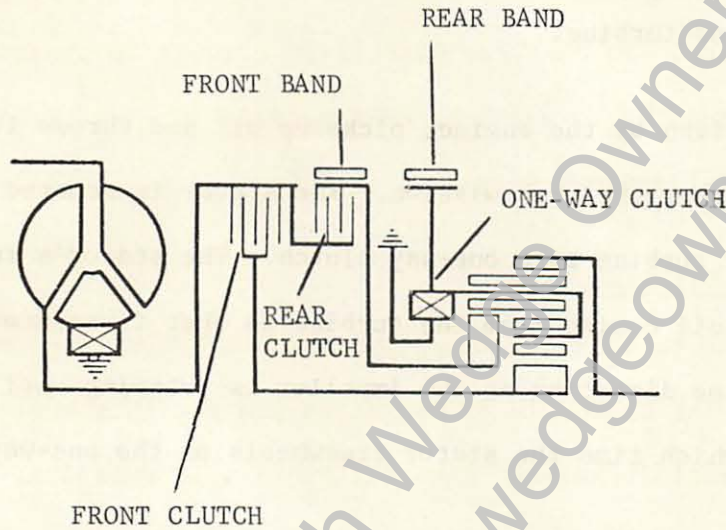

	FC	RC	FB	RB	1-way clutch
1 (first gear)	●			●	
D (first gear)	●				●
2 & D (sec. gear)	●		●		
D (third gear)	●	●			
R (reverse gear)		●		●	
*P (park)				●	

\* When engine running



## MECHANICAL POWER FLOW

### NEUTRAL AND PARK

In NEUTRAL the FRONT and REAR clutches are OFF and no power is transmitted from the convertor to the gear set. The FRONT and REAR bands are also released. In PARK the REAR servo circuit is pressurized while the engine is running so that the REAR band is applied, (this is due to constructional reasons only).

### FIRST GEAR 'D' SELECTED

The FRONT clutch is APPLIED connecting the CONVERTOR to primary sun gear. The ONE-WAY CLUTCH is in operation preventing the PLANET CARRIER from rotating anticlockwise. When the vehicle is coasting, the ONE-WAY CLUTCH overruns and the gear set freewheels.

### APPLIED

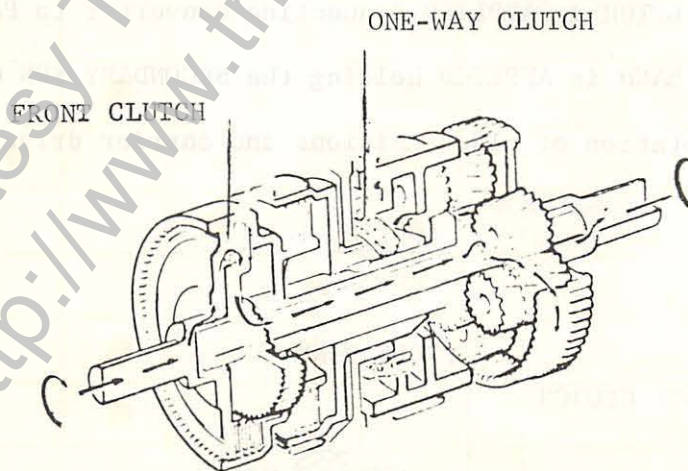

FIRST GEAR '1' SELECTED

The FRONT clutch is APPLIED connecting CONVERTOR to PRIMARY SUN GEAR.  
The REAR BAND is APPLIED holding the planet carrier stationary. Planet pinions drive RING GEAR and SECONDARY SUN GEAR rotates FREELY in the opposite direction to the PRIMARY SUN GEAR.

APPLIED

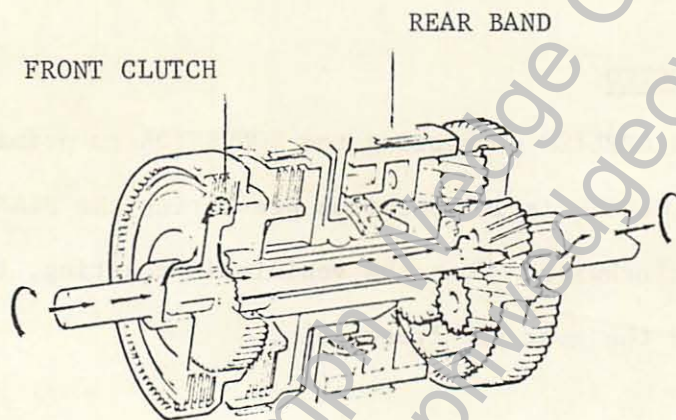

SECOND GEAR 'D', '2' or '1' SELECTED

Again the FRONT CLUTCH is APPLIED connecting convertor to PRIMARY SUN GEAR. The FRONT BAND is APPLIED holding the SECONDARY SUN GEAR stationary. Combined rotation of planet pinions and carrier drive the ring gear.

APPLIED

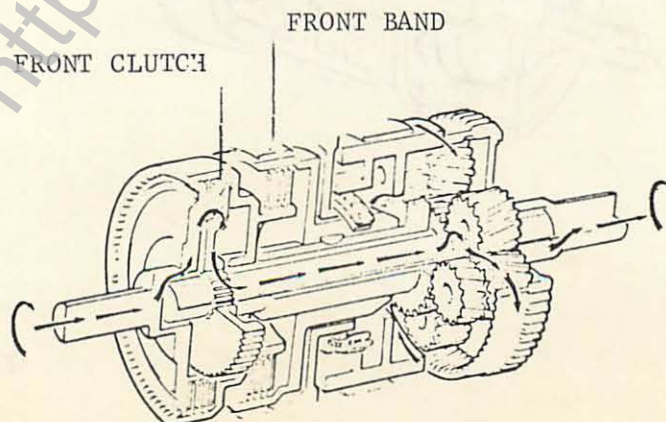



THIRD GEAR 'D' SELECTED

Again the FRONT CLUTCH is APPLIED connecting convertor to PRIMARY SUN GEAR. The REAR CLUTCH is APPLIED connecting the convertor also to the SECONDARY SUN GEAR, thus locking both sun gears together and the gear set rotates as a unit providing a 1:1 ratio.

APPLIED

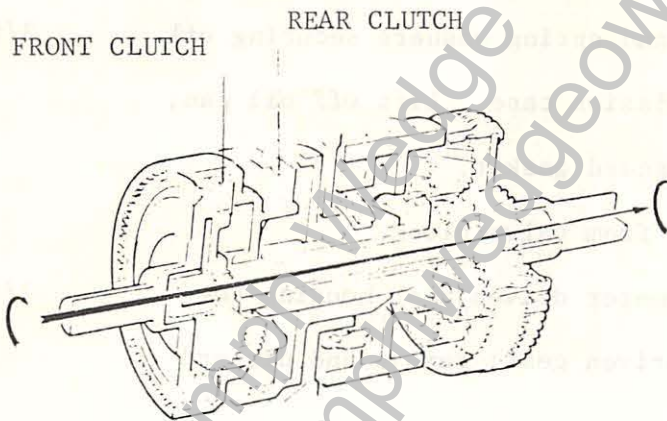

REVERSE GEAR 'R' SELECTED

The REAR CLUTCH is APPLIED connecting convertor to SECONDARY SUN GEAR. The REAR BAND is APPLIED holding planet carrier stationary. Planet pinions drive RING GEAR in an opposite direction to engine rotation.

APPLIED

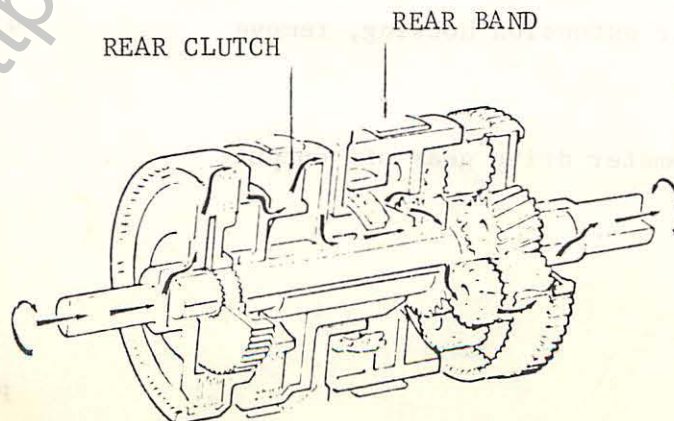

## TRANSMISSION ASSEMBLY

### DISMANTLE TRANSMISSION

### TOOL

1. Remove torque convertor housing. 11/16" & 3/4" socket
2. Invert transmission.
3. Position selector lever in 'P' (Park). Adjustable wrench  
(Turn shaft clockwise.)
4. Remove bolts and spring washers securing oil 3/8" socket  
pan to transmission case. Lift off oil pan;  
remove and discard gasket.
5. Remove magnet from valve block.
6. Remove speedometer driven gear housing to- 7/16" wrench  
gether with driven gear; remove and discard  
'O' ring.
7. Remove bolt and plain washer securing out- 3/4" socket  
put flange; withdraw flange.
8. Note fitted position of bolts, stud bolts and 7/16" socket  
spacers. Remove bolts, stud bolts, plain washers 9/16" open wrench  
and spacers securing rear extension housing to 7/16" wrench  
transmission case.
9. Withdraw rear extension housing, remove 9/16" socket  
gasket.
10. Slide speedometer drive gear off output  
shaft.



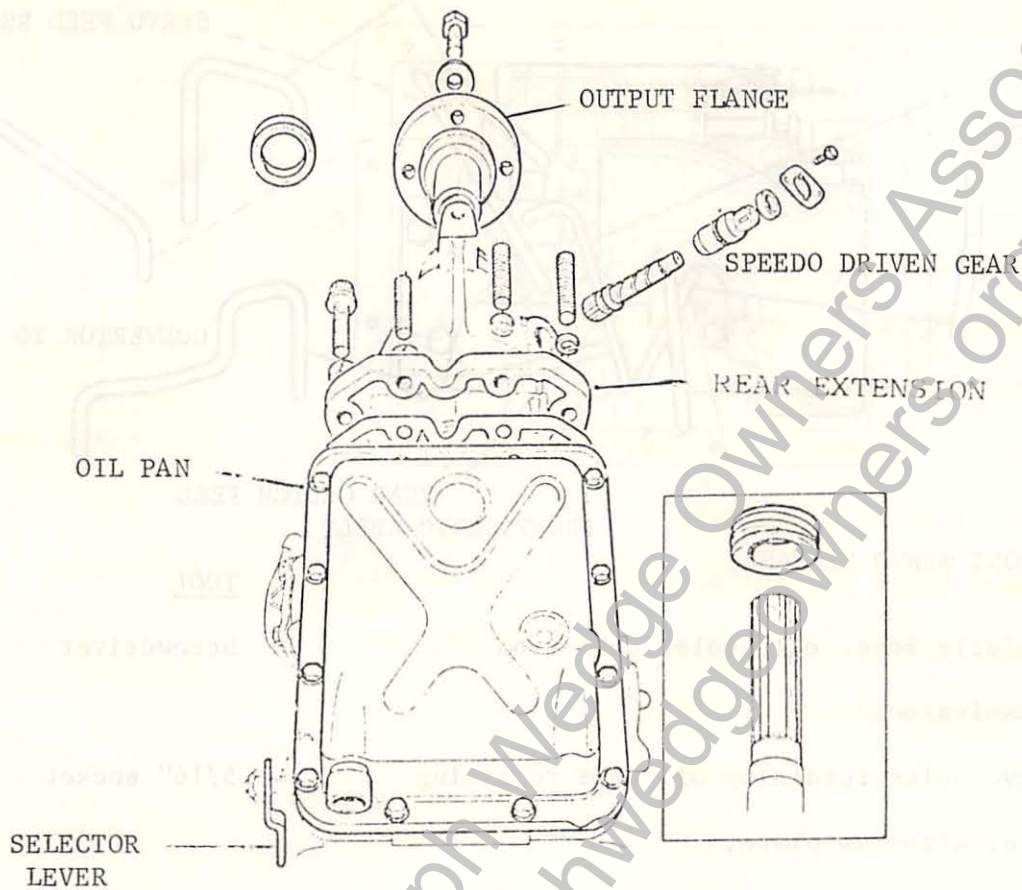

TOOL

11. Note fitted positions of oil tubes and using a suitable screwdriver, carefully lever tubes, with the exception of tube (converter to cooler), out of transmission and governor tubes. Screwdriver
12. Remove bolts and spring washers securing valve block noting that shortest bolt is fitted at front of valve block. 7/16" socket
13. Disconnect kickdown cable from cam. Lift off valve block taking care that manual valve is not displaced. Screwdriver

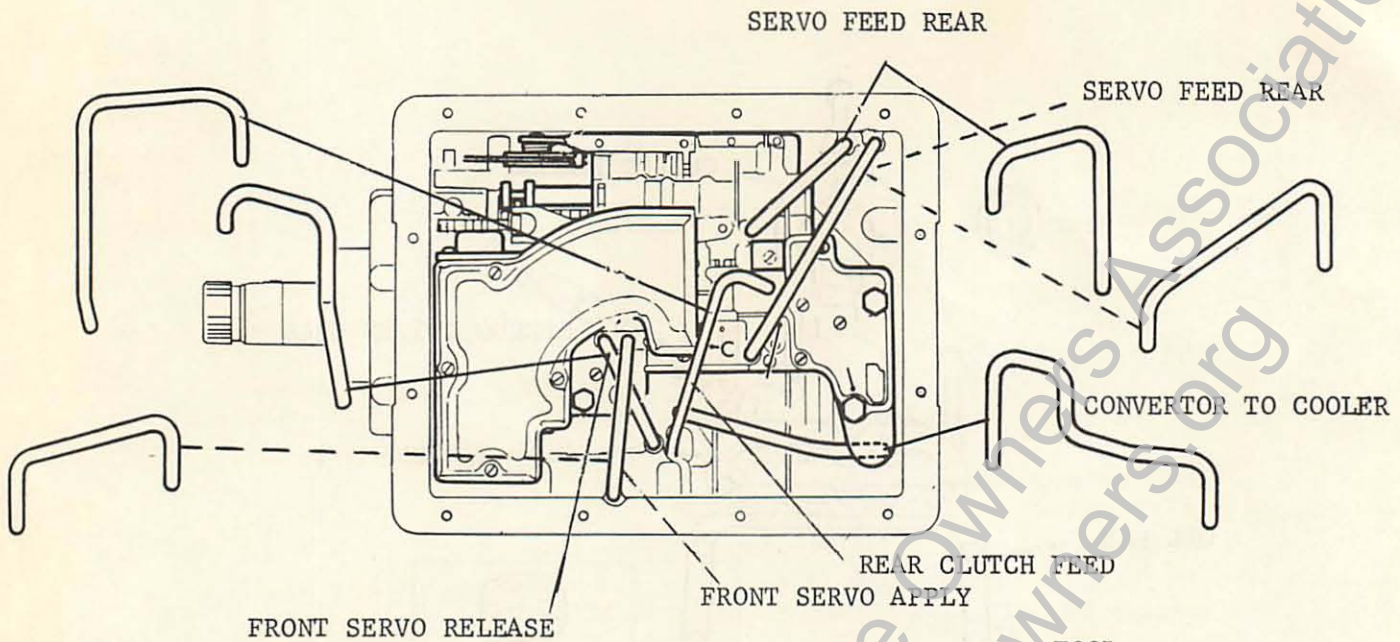

TOOL

- |  |              |
|--|--------------|
| 14. Carefully lever oil cooler tube from transmission.               | Screwdriver  |
| 15. Remove bolts retaining oil tube retaining plate; withdraw plate. | 5/16" socket |
| 16. Withdraw pump inlet tube; remove and discard 'O' ring.           | Pliers       |
| 17. Withdraw pump outlet pipe.                                       |              |
| 18. Withdraw convertor feed tube.                                    |              |

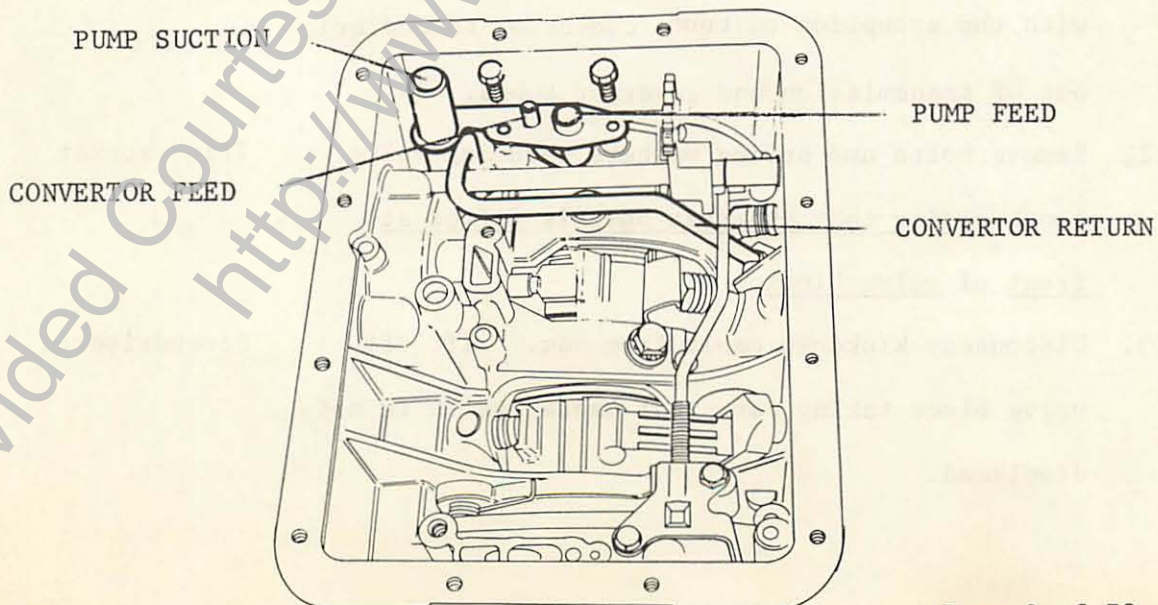



- |   | <u>TOOL</u>                 |
|---|-----------------------------|
| 19. Check gear train end float.   | End float gauge             |
| 20. Scribe alignment marks on transmission case and oil pump.   | Scribe                      |
| 21. Remove bolts and wave washers securing oil pump to transmission case.                                   | 1/2" socket                 |
| 22. Withdraw oil pump. Remove plug and spring washer securing governor on output shaft.                     | 1 1/8" socket               |
| 23. <u>Note</u> fitted position of governor; slide governor off output shaft.                               |                             |
| 24. Carefully lever governor feed tube, governor return tube and lubrication tube out of transmission case. | Screwdriver                 |
| 25. Slacken locknut and unscrew front brake band adjuster screw; recover brake band strut.                  | 3/4" socket<br>5/16" wrench |
| 26. Slacken locknut and unscrew rear brake band adjuster screw; recover brake band strut.                   |                             |

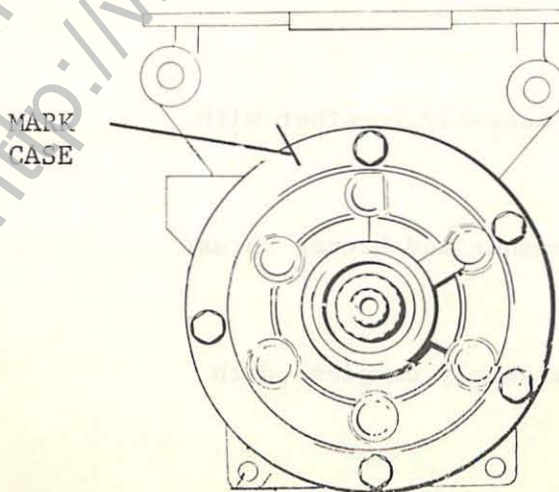

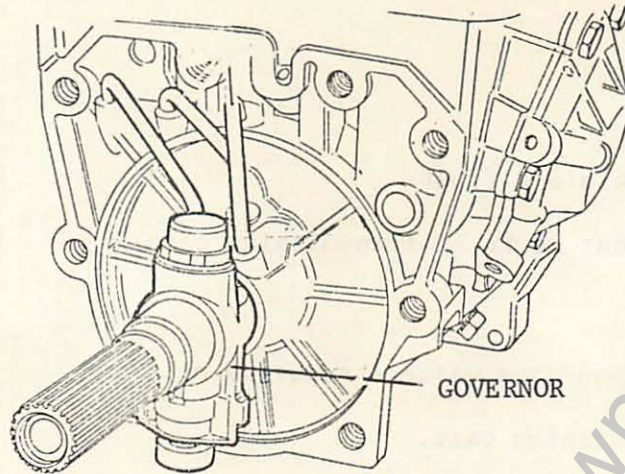

GOVERNOR

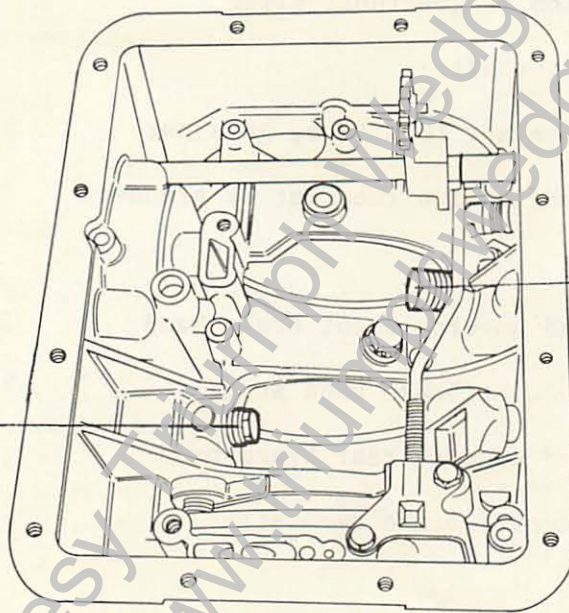

BAND ADJUSTMENT  
SCREW

BAND ADJUST-  
MENT SCREW

27. Withdraw front clutch assembly together with input shaft.
28. Remove steel backing washer and bronze thrust washer.
29. Withdraw rear clutch assembly complete with primary sun gear.



TOOL

30. Note fitted position of front brake band;  
compress and withdraw brake band and strut.
31. Remove bolts and lockwashers securing center support. 9/16" socket
32. Push output shaft forwards to displace center support and sun gear assembly.
33. Withdraw center support and sun gear assembly from transmission case.
34. Separate center support from sun gear assembly.
35. Note fitted position of rear brake band; compress and withdraw brake band and strut.
36. Withdraw output shaft and ring gear assembly and thrust washer.

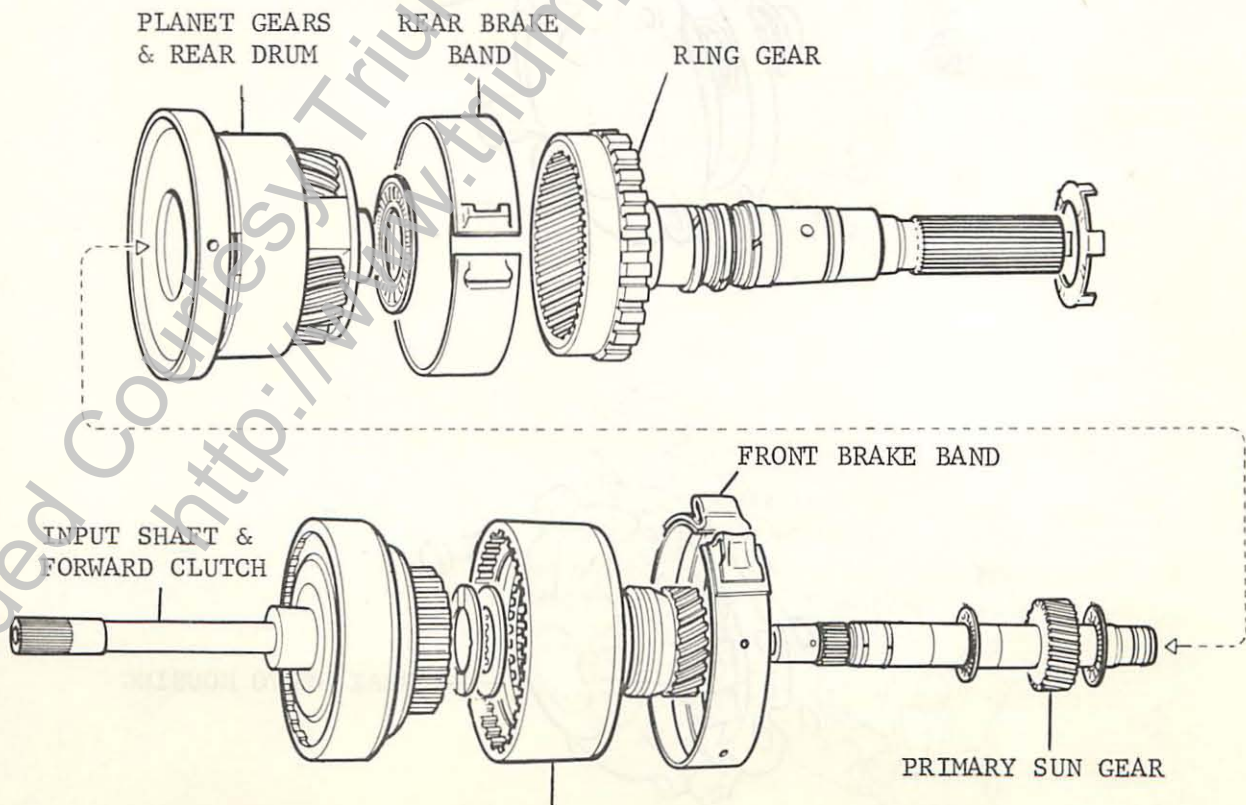

TOOL

37. Remove bolts securing front servo to transmission case. Withdraw front servo, operating rod and spring; remove and discard gasket. 1/2" socket
38. Scribe alignment marks on rear servo and transmission case. Scribe
39. Remove bolts securing rear servo to transmission case. Withdraw rear servo together with operating rod and spring. 1/2" socket
40. Inspect park mechanism.

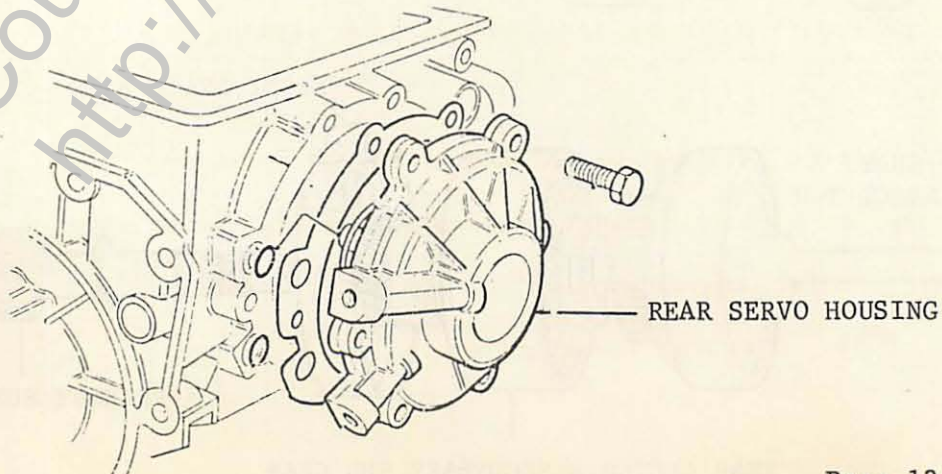
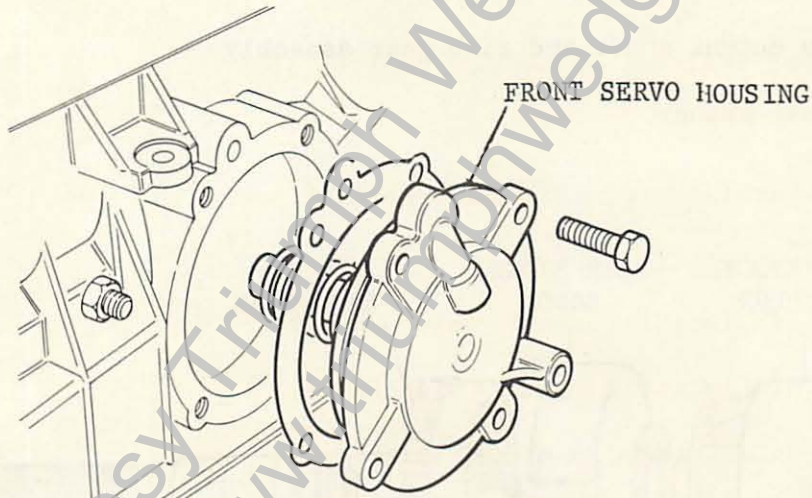



TORSION SPRING

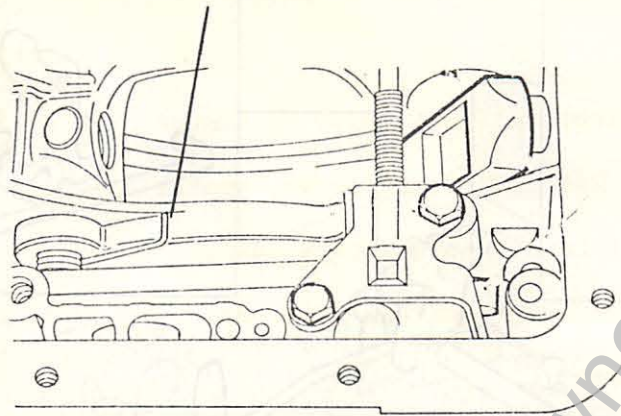

IF IT IS FOUND NECESSARY TO DISMANTLE PARKING  
PAWL ASSEMBLY, PROCEED AS FOLLOWS:

1. Note fitted position of parking pawl torsion spring.
2. Withdraw parking pawl pivot pin; collect pawl and torsion spring.
3. Release clip locating manual valve lever.
4. Withdraw pin locating manual valve lever.
5. Withdraw detent shaft; collect manual valve lever, spacer and plain washers; remove and discard 'O' ring and oil seal.
6. Release parking brake rod assembly from parking pawl.
7. Note fitted position of parking brake rod operating lever and torsion spring, release spring from lever.
8. Using suitable punch, drive out operating lever pivot pin; withdraw lever and spring.

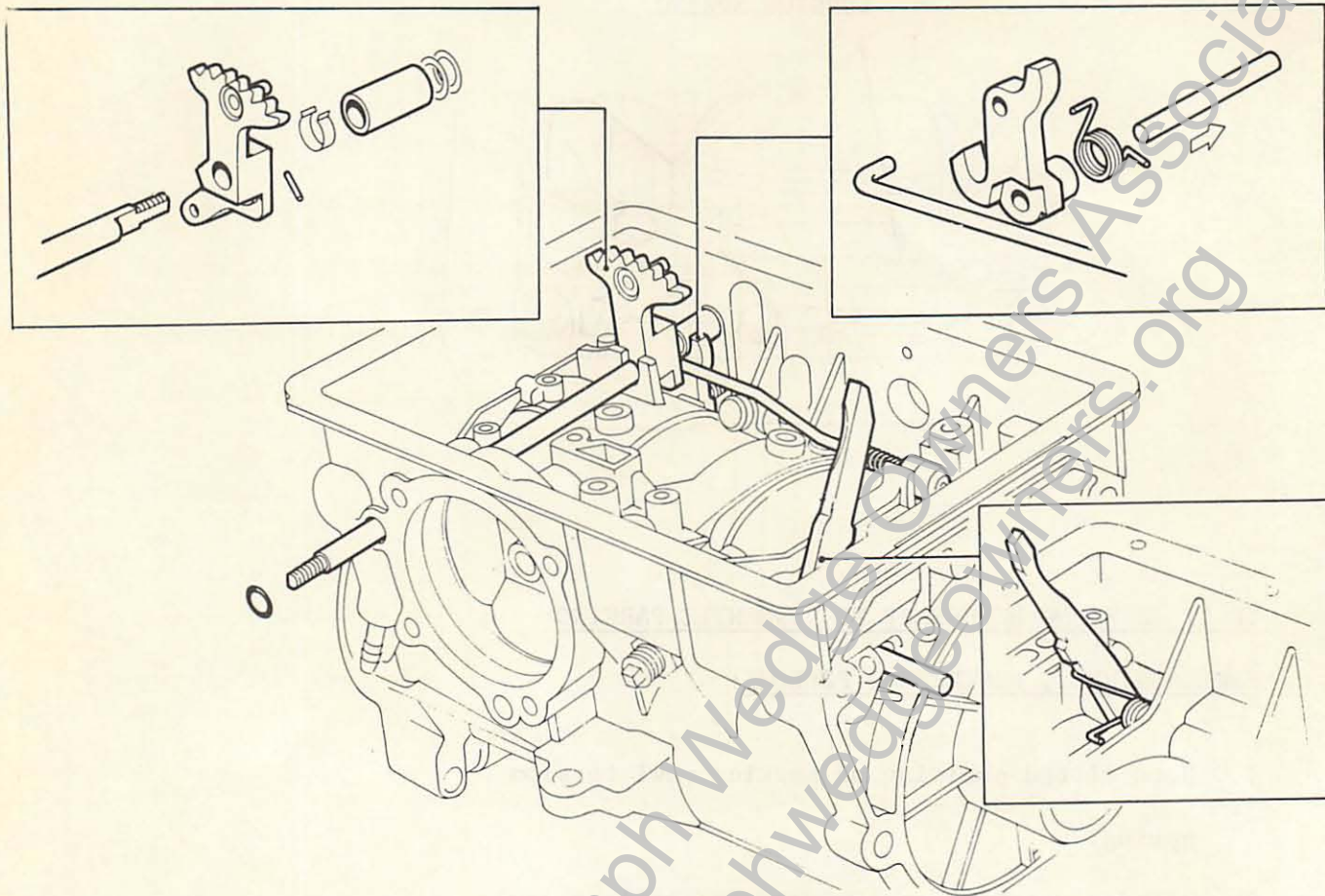

TOOL

IF IT IS FOUND NECESSARY TO REMOVE KICKDOWN

CABLE ASSEMBLY, PROCEED AS FOLLOWS:

1. Using Service Tool CBW.62 compress lugs of cable retaining plug. CBW.62
2. Withdraw kickdown cable assembly; remove and discard O ring.

CAUTION. It is not possible to remove retaining plug from kickdown cable assembly and if lugs are broken, cable assembly must be replaced.



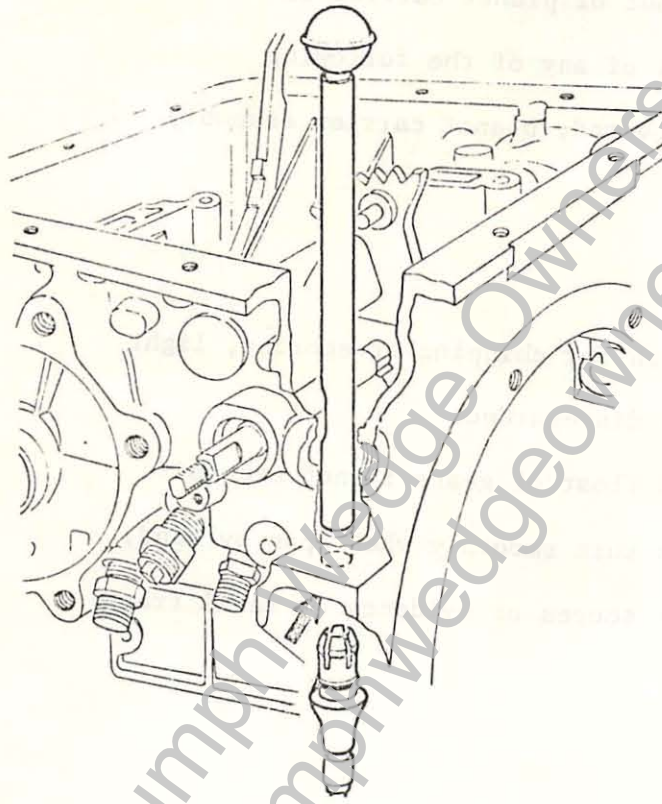

## PLANET CARRIER

CAUTION: No overhaul of planet carrier is possible. In event of any of the following defects being discovered, planet carrier assembly must be replaced.

### Inspection

1. Check gear teeth for chipping or scoring, light scoring may be disregarded.
2. Check that end float of gears is not excessive and that gears turn smoothly when spun by hand.
3. Check bush for scores or evidence of metal transfer.

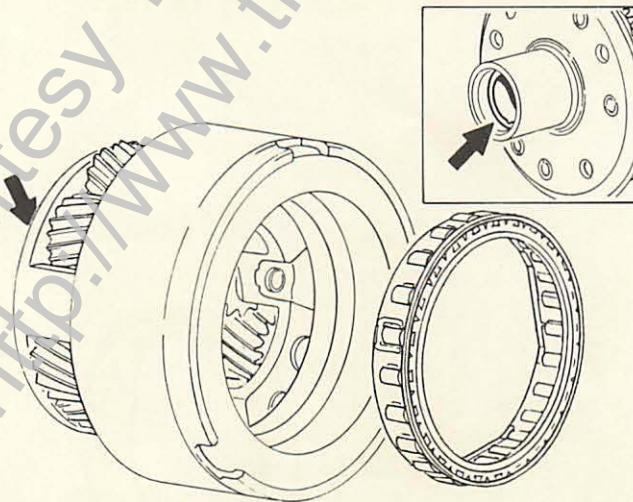



### ONE-WAY CLUTCH

CAUTION: No overhaul of one-way clutch is possible. In the event of any of the following defects being discovered, one-way clutch must be replaced.

#### Dismantle

1. Note fitted position of one-way clutch.
2. Withdraw clutch from planet carrier.

#### Inspection

3. Check faces for scoring or discoloration.
4. Check sprag faces for flat spots indicating wear.

#### Reassemble

5. Push one-way clutch into planet carrier, ensure that lip faces outwards and that clutch is fully seated in recess.

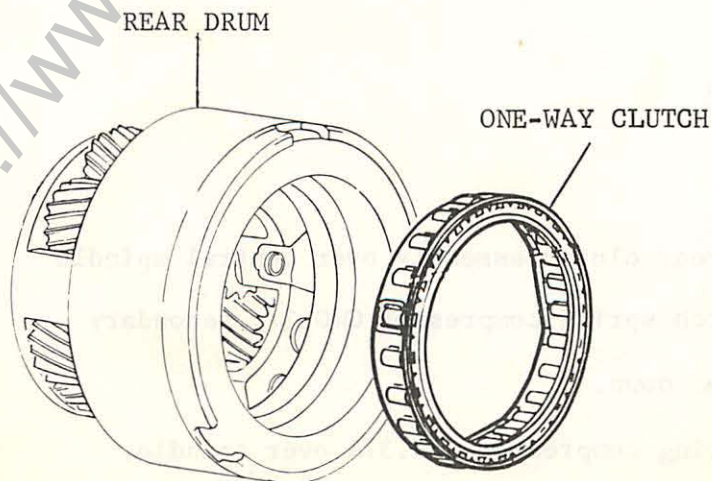

PRIMARY SUN GEAR SHAFT

TOOL

Inspection

1. Check drillings in shaft for obstruction; clear with compressed air only.
2. Check splines, sealing ring grooves and gear teeth for burrs or signs of damage; replace if damaged. Minor burrs may be removed with a very fine abrasive.
3. Examine large and small needle roller bearings; replace if either show signs of wear or damage.

NOTE: Some applications include a lubrication valve in the shaft - Jaguar XJ6 does.

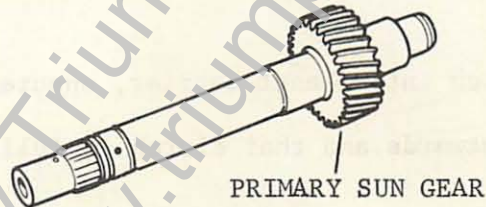

REAR CLUTCH

Dismantle

1. Place rear clutch assembly over central spindle of clutch spring compressor CWG.37, secondary sun gear down.
2. Fit spring compressor CBW.37A over spindle.

CWG.37

CBW.37A



3. Compress spring and remove snap ring.
4. Slowly release pressure and remove compressor.
5. Remove retainer and spring.
6. Remove snap ring retaining pressure plate.
7. Remove pressure plate.
8. Remove inner and outer clutch plates.

TOOL

Cirelip pliers -  
Screwdriver

Screwdriver

NOTE: Five outer and five inner clutch plates  
are fitted to Jaguar XJ6s.

9. Remove piston by applying air pressure to supply  
hole in clutch housing pedestal.

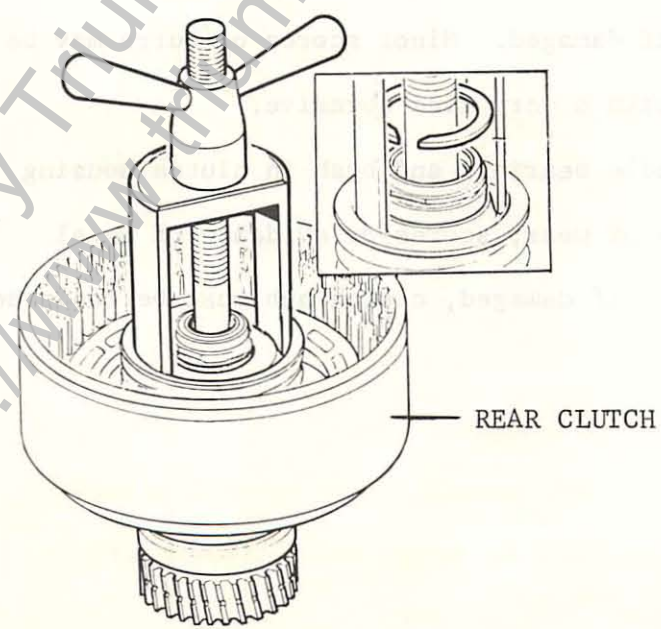

TOOL

Inspection

10. Check clutch drum and bearing surfaces for scores or burrs; replace drum if damaged.
11. Check fluid passages for obstructions, clear passages with compressed air only.
12. Inspect piston check valve for free operation.
13. Check clutch release spring for distortion; replace if distorted.
14. Check inner clutch plates for flatness and that facings are undamaged.
15. Check that coning on outer clutch plates is not less than .010 in. Feeler gauge
16. Check outer clutch plates for scores or burrs; replace if damaged. Minor scores or burrs may be removed with a very fine abrasive.
17. Check needle bearings and bush in clutch housing for signs of wear, scores or evidence of metal transfer. If damaged, clutch hub must be replaced.



Provided Courtesy Triumph Wedge Owners Association  
<http://www.triumphwedgeowners.org>

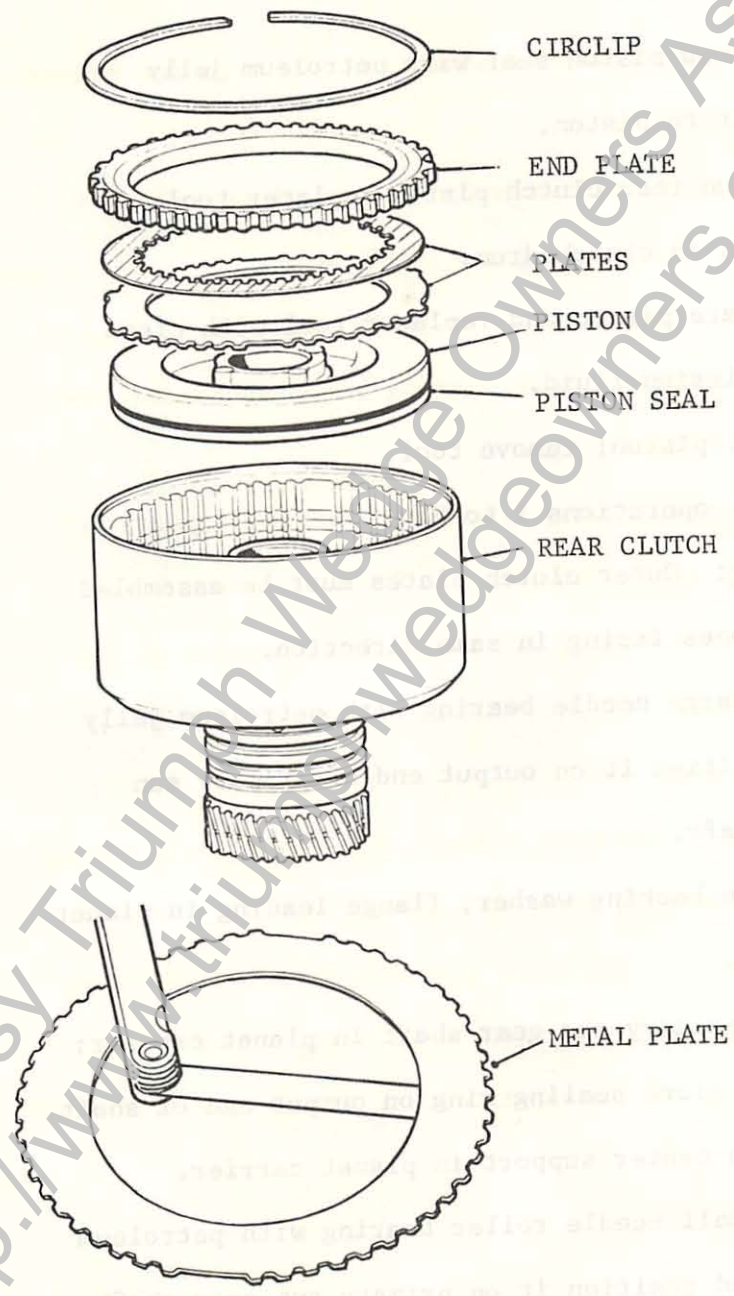

TOOL

Reassemble

18. Smear new piston seal with petroleum jelly and fit to piston.
19. Position rear clutch piston replacer tool CBW.41A in clutch drum.
20. Lubricate piston and replacer tool with clean transmission fluid.
21. Install piston; remove tool.
22. Reverse operations 1 to 8.  
CAUTION: Outer clutch plates must be assembled with cones facing in same direction.
23. Smear large needle bearing with petroleum jelly and position it on output end of primary sun gear shaft.
24. Position backing washer, flange leading in planet carrier.
25. Insert primary sun gear shaft in planet carrier; fit new fibre sealing ring on output end of shaft.
26. Position center support in planet carrier.
27. Smear small needle roller bearing with petroleum jelly and position it on primary sun gear shaft.
28. Position rear clutch assembly on primary sun gear shaft; fit new sintered sealing rings on input end of shaft. Ensure gaps in sealing rings are staggered.



CAUTION: Do not remove rear clutch assembly  
and primary sun gear shaft from planet carrier.

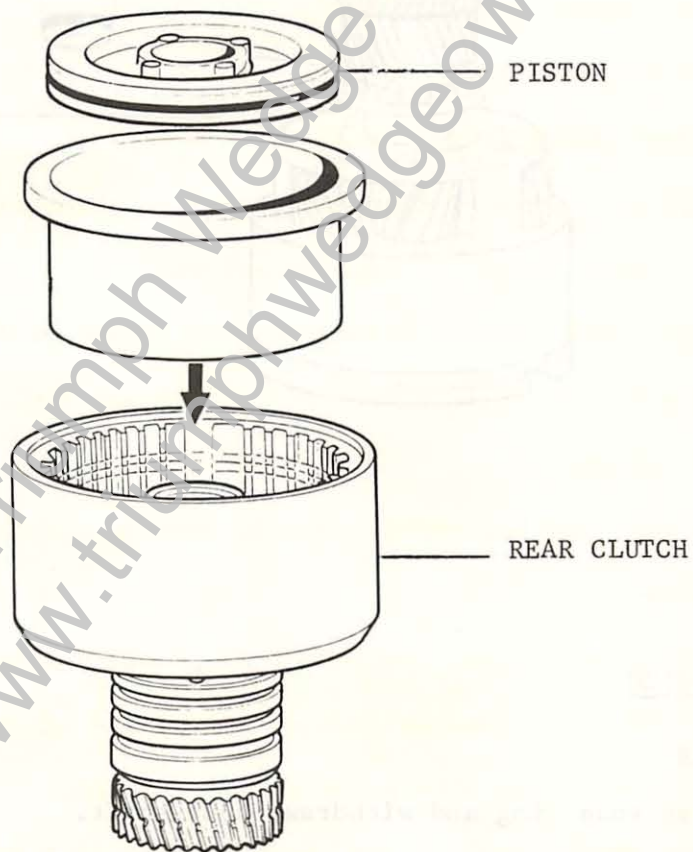

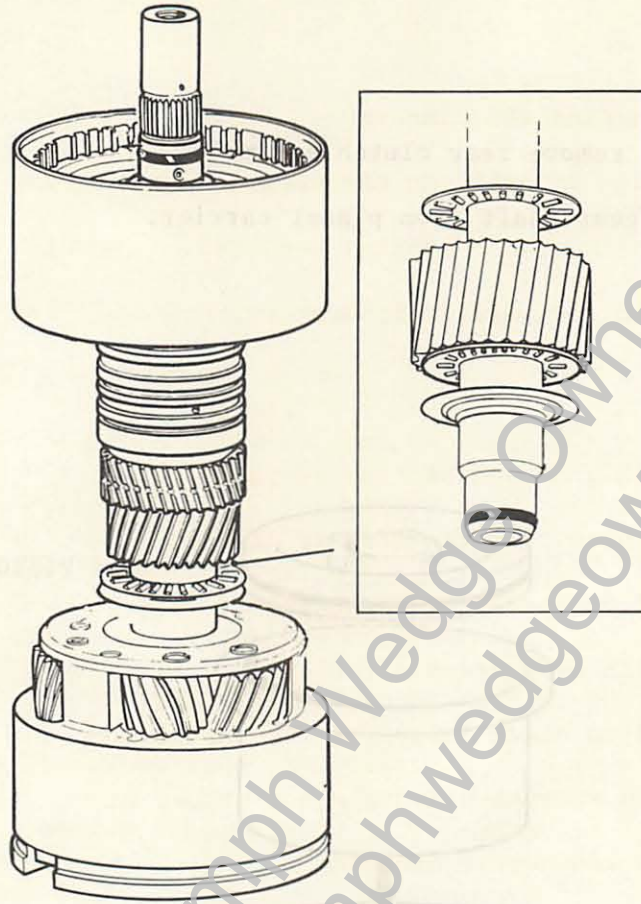

FRONT CLUTCH

Dismantle

1. Remove snap ring and withdraw input shaft.
2. Remove bronze thrust washer.
3. Remove clutch hub.
4. Remove inner and outer clutch plates and ring gear.

NOTE: Four outer and five inner clutch plates are fitted on Jaguar XJ6.

TOOL

Circlip pliers -  
Screwdriver



TOOL

Screwdriver

5. Remove snap ring and diaphragm.
6. Remove piston by applying air pressure to supply hole in clutch housing pedestal.
7. Remove plain and Belleville washers.

Inspection

8. Check clutch drum and bearing surfaces for scores or burrs; replace drum if damaged.
9. Check fluid passages for obstruction; clear passages with compressed air only.
10. Inspect piston check valve for free operation.
11. Check clutch release diaphragm for cracks or distortion; replace if damaged.
12. Check inner clutch plates for flatness and that facings are undamaged.

NOTE: There is no coning on clutch plates.

13. Check outer clutch plates for flatness, scores or burrs; replace if damaged. Minor scores or burrs may be removed with a very fine abrasive.
14. Check bush in input shaft for scores or evidence of metal transfer. If damaged, input shaft must be replaced.

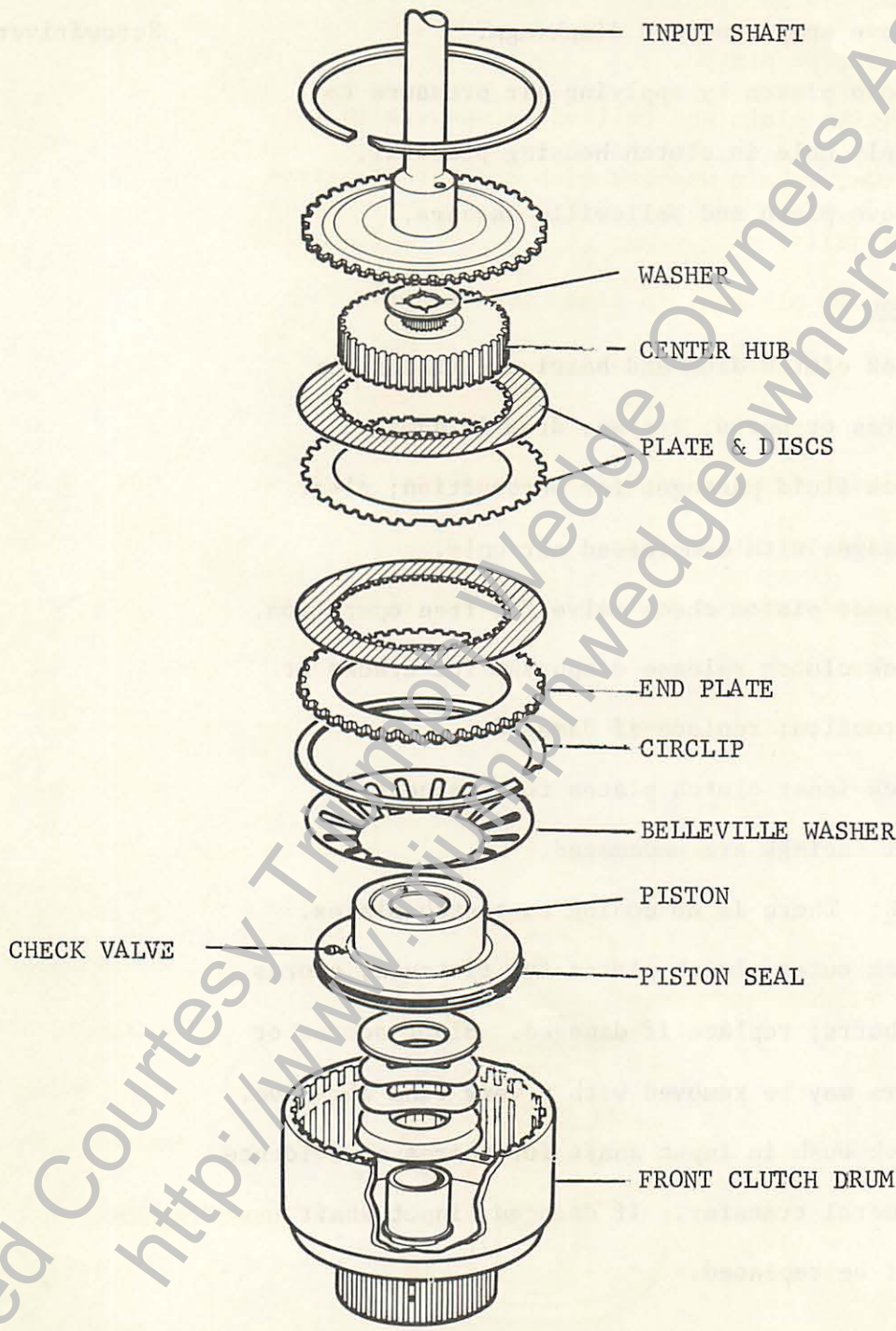

Provided Courtesy Trimble  
<http://www.wedgewedgeowners.org>



TOOL

15. Smear new 'O' ring with petroleum jelly and fit to piston.
16. Position plain and Belleville washers in piston, retain washers with a smear of petroleum jelly.
17. Soak new oil seal in clean transmission fluid and insert in piston.

NOTE: Open end of seal faces outwards.

18. Position front clutch piston replacer tool CBW.42A in clutch drum.
19. Lubricate piston and replacer tool with clean transmission fluid.
20. Install piston; remove tool.

CBW.42A

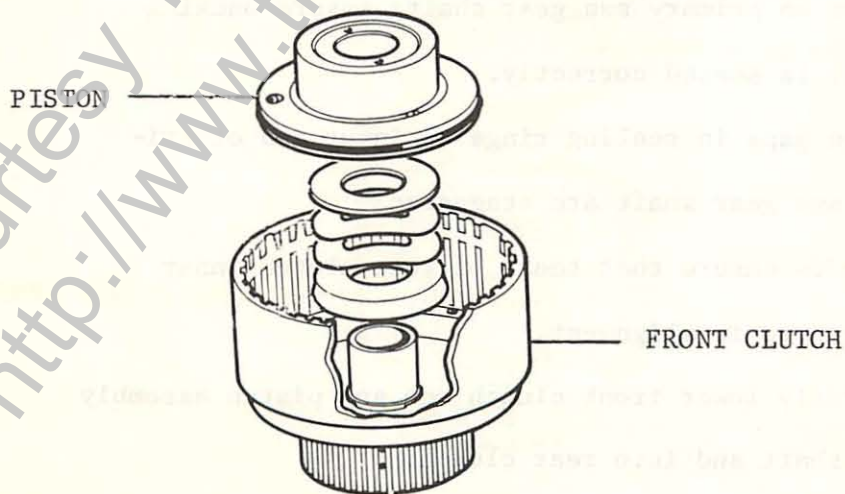

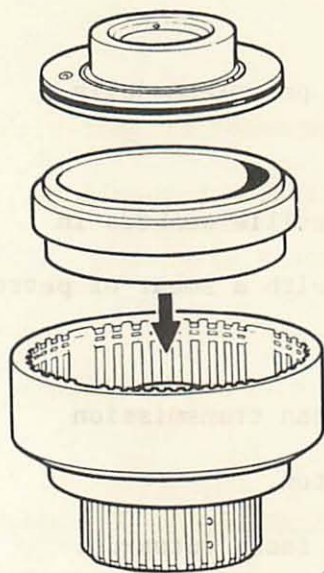

21. Fit release diaphragm.
22. Fit snap ring; ensure ring is correctly seated in groove.
23. Fit steel backing washer and new bronze thrust washer on primary sun gear shaft; ensure backing washer is seated correctly.
24. Ensure gaps in sealing rings on input end of primary sun gear shaft are staggered.
25. Check to ensure that teeth of rear clutch inner plates are in alignment.
26. Carefully lower front clutch hub and piston assembly over shaft and into rear clutch.



NOTE: To facilitate engagement of gear with rear clutch plates, front clutch should be moved backwards and forwards slightly.

27. Fit end plate.
28. Position inner and outer clutch plates in clutch drum.

NOTE: For identification purposes, two pairs of teeth at  $180^{\circ}$  have been omitted on outer clutch plates.

29. Check to ensure that teeth of inner clutch plates are in alignment.
30. Fit clutch hub; ensure hub fully engages all clutch plates.
31. Position new bronze thrust washer in recess in clutch hub.
32. Fit input shaft and snap ring; ensure snap ring is correctly seated in groove.

CAUTION: On no account should front and rear clutch assemblies be separated as damage to sealing rings on primary sun gear shaft will result.

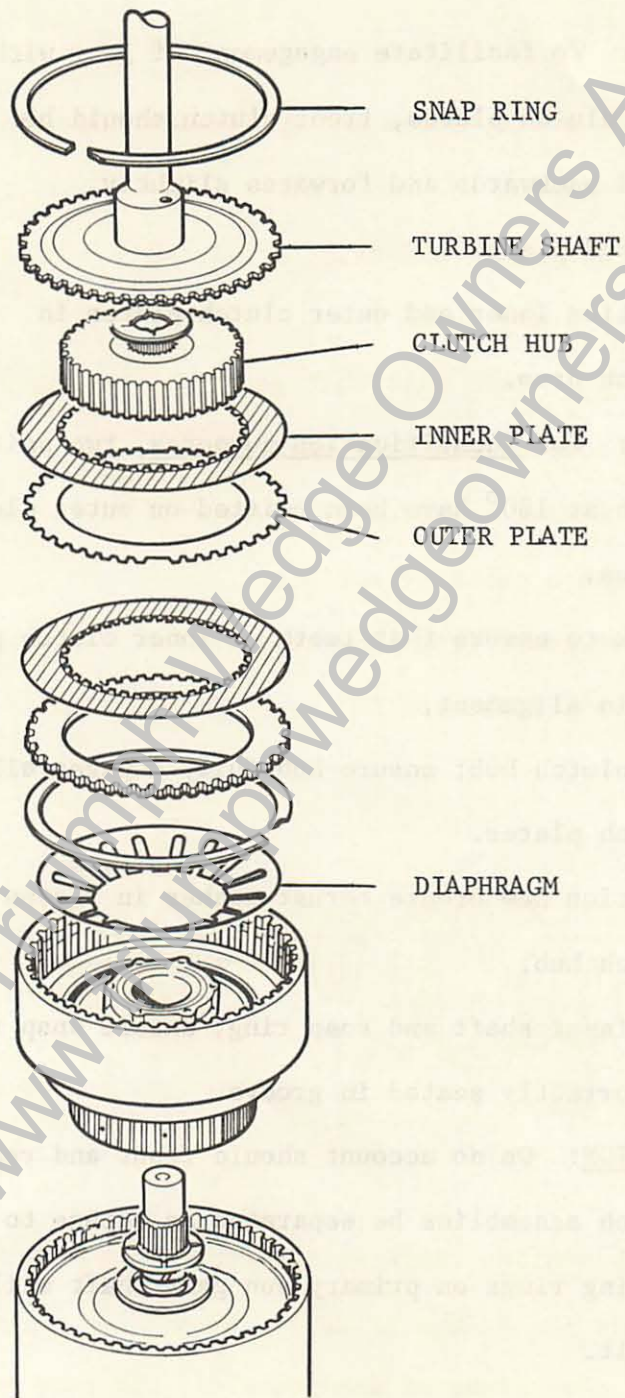

Provided Courtesy Trimble Wedge Owners Association  
<http://www.trimblewedgeowners.org>



## OIL PUMP

### TOOL

### Dismantle

1. Remove bolts, screw and spring washers securing pump adaptor to pump body. 1/2" socket - Screwdriver
  2. Hold pump body and using a hide mallet, gently tap convertor tube. Hide mallet
- CAUTION: Take care that gears are not displaced when adaptor and body separate.
3. Mark mating surfaces of gears with die marker, DO NOT use a punch or scriber. Die marker
  4. Remove gears from pump body.
  5. Remove and discard 'O' ring and oil seal.

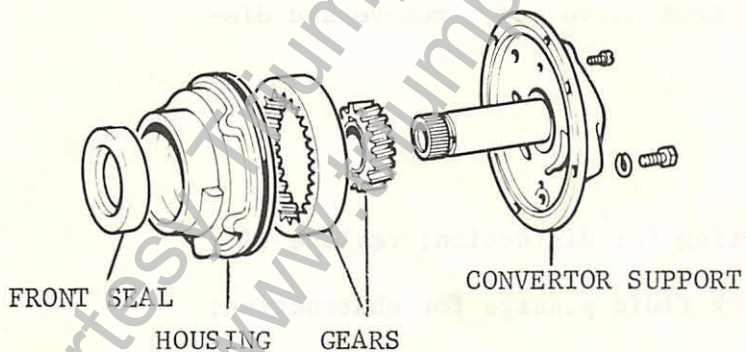

6. Check bearing surfaces, gears, splines and bushes for damage or wear. Should any component show signs of damage, etc., oil pump assembly must be renewed.

### Reassemble

7. Soak new oil seal in clean transmission fluid and

TOOL

press carefully into pump body; ensure seal is squarely seated.

8. Soak new 'O' ring in clean transmission fluid and position in groove in periphery of pump body.
9. Reverse operations 1 to 4 ensuring reference marks on gears, adaptor and body are in alignment. 1/2" socket - Screwdriver
10. Progressively tighten bolts to a torque of 2.5 lb. ft.

FRONT SERVO

Dismantle

1. Remove piston return spring.
2. Withdraw piston from servo body; remove and discard 'O' rings.

Inspection

3. Check return spring for distortion; replace if necessary. Check fluid passage for obstruction; clear passage with compressed air only.

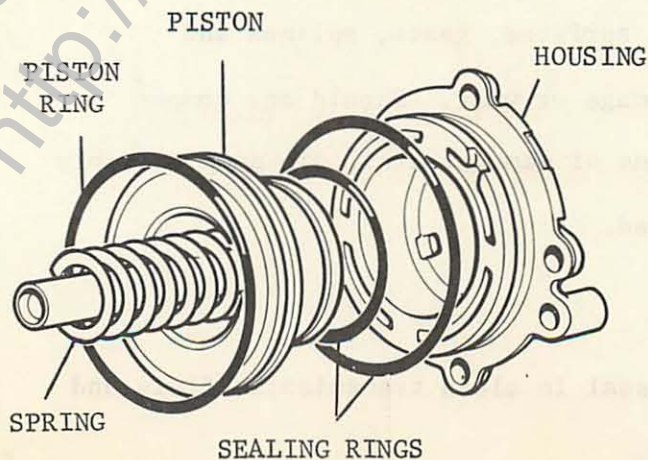



Reassemble

4. Reverse operations 1 and 2; coat new 'O' rings with petroleum jelly prior to fitting.

REAR SERVO

Dismantle

1. Withdraw piston from servo body; remove and discard 'O' rings.

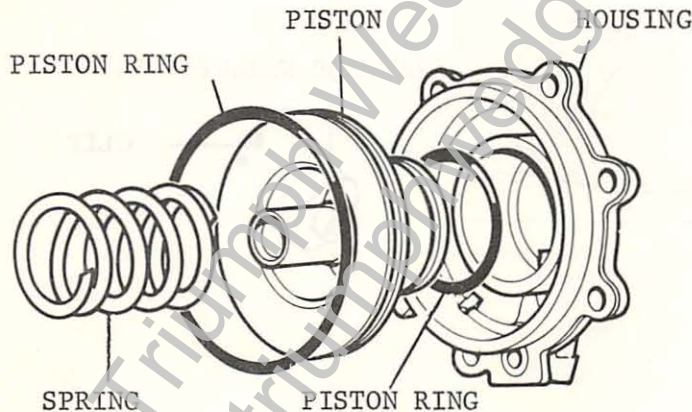

Inspection

2. Check return spring for distortion, replace if necessary.
3. Check fluid passages for obstruction; clear passages with compressed air only.

Reassemble

4. Reverse operation 1; coat new 'O' rings with petroleum jelly prior to fitting.

TOOL

GOVERNOR

Dismantle

1. Depress governor weight stem to expose circlip.
2. Remove circlip and weight, discard circlip. Circlip pliers
3. Withdraw stem, spring and valve from governor body.

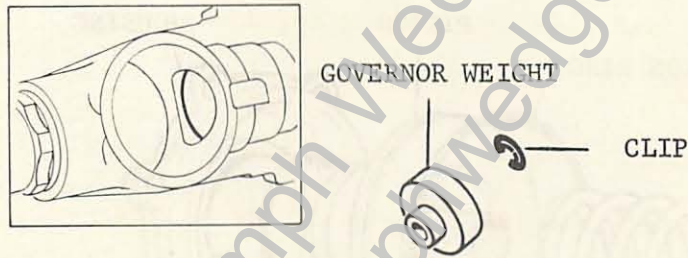

Inspection

4. Check all components for signs of damage and additionally, check spring for distortion. In the event of any component being found unsatisfactory, governor assembly must be renewed.

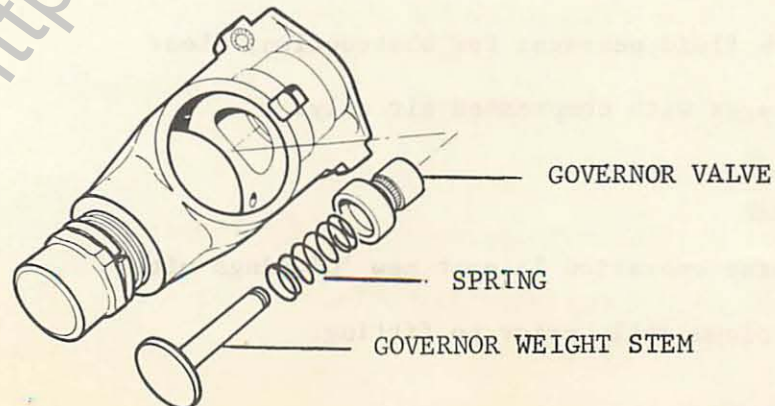



TOOL

Reassemble

5. Reverse operations 1 to 3; use a new circlip.
6. Check weight stem for free movement.

CAUTION: If weight stem shows signs of sticking, governor assembly must be replaced.

BRAKE BANDS

Inspection

1. Check front and rear brake bands for damage or distortion.
2. Check linings for uneven or excess wear.

CAUTION: Bands must be replaced if any of the defects detailed above are apparent or if doubt exists as to their condition.

OUTPUT SHAFT AND RING GEAR

Dismantle

1. Remove and discard sealing rings from output shaft.
2. Remove snap ring retaining output shaft; withdraw shaft.

Screwdriver

Inspection

3. Check drillings in output shaft for obstruction; clear with compressed air only.

TOOL

4. Check splines, sealing ring grooves and gear teeth for burrs or signs of damage; replace if damaged. Minor burrs may be removed with a very fine abrasive.
5. Check bush for scores or evidence of metal transfer. Should damage be evident, output shaft must be replaced.

Reassemble

6. Reverse operations 1 and 2.

Screwdriver

CAUTION: Ensure gaps in sealing rings are staggered.

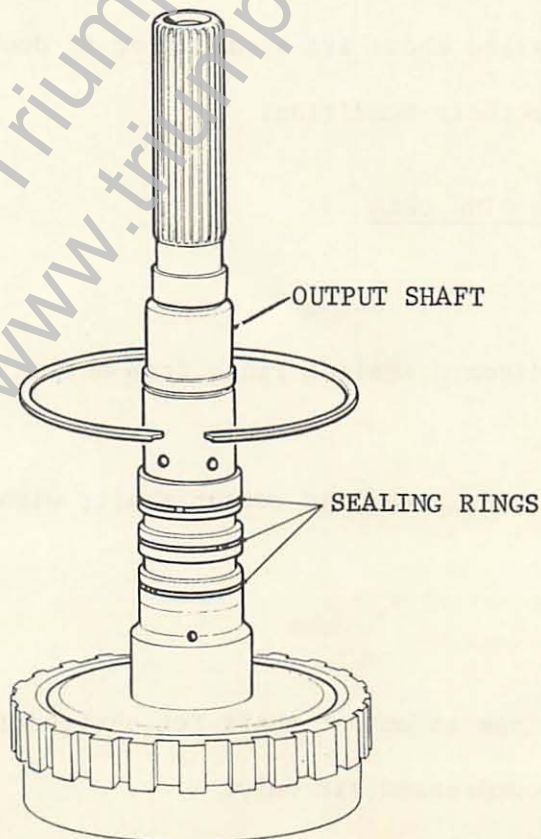



TOOL

GEAR CASE

Inspection

1. Remove oil cooler return union together with non-return valve assembly (if fitted). 9/16" wrench
2. By means of a piece of thin wire, check operation of ball valve. Valve should operate smoothly and seat fully. Check bush in gear case for scores, burrs or transfer of metal. Thin Wire

NOTE: Smear threads of union with Loctite Grade AV before refitting.

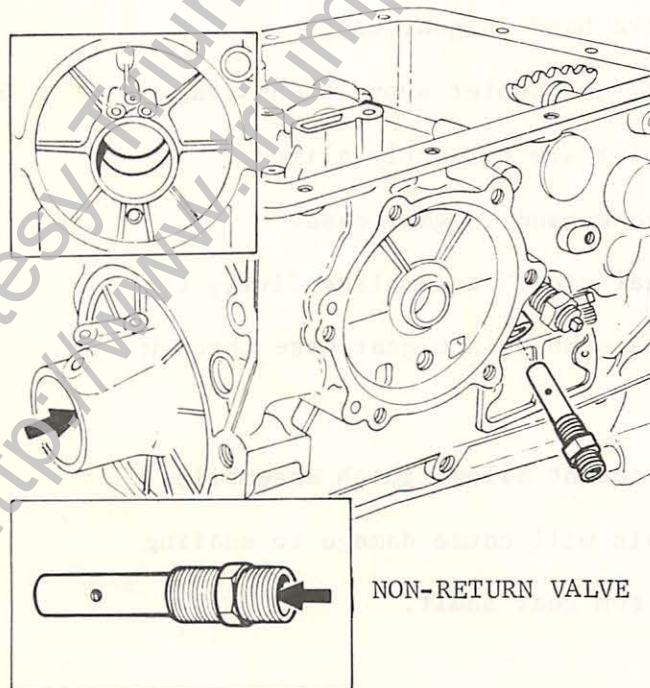

TRANSMISSION ASSEMBLY

TOOL

Reassemble

1. If kickdown cable was removed, smear new 'O' ring with petroleum jelly; position 'O' ring on retaining plug.
2. Pass cable into gear case and push retaining plug fully home. Ensure lugs of retaining plug are correctly located in gear case.
3. Smear large bronze thrust washer with petroleum jelly and position thrust washer, lugs leading, in gear case. Ensure lugs on thrust washer are located on gear case.
4. Fit output shaft and ring gear assembly taking care that thrust washer is not displaced.
5. Position rear brake band in gear case.
6. Fit planet carrier and center support ensuring center support holes are correctly aligned.
7. Position front brake band in gear case.
8. Hold front and rear clutch assemblies firmly together and enter assembly into gear case through front aperture.

9/16" wrench

CAUTION: On no account allow clutch assemblies to separate as this will cause damage to sealing rings on primary sun gear shaft.



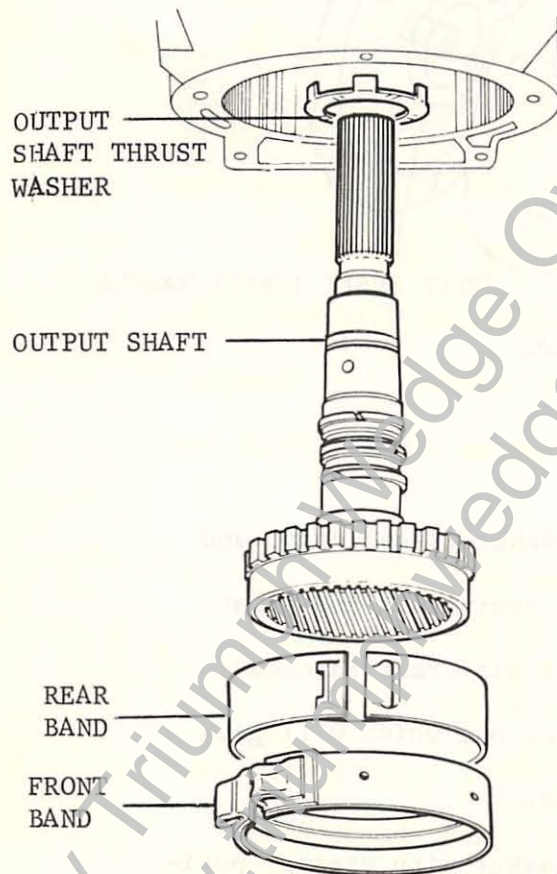

- 9 Position new bronze thrust washer on oil pump;  
ensure that lugs on washer face towards pump.

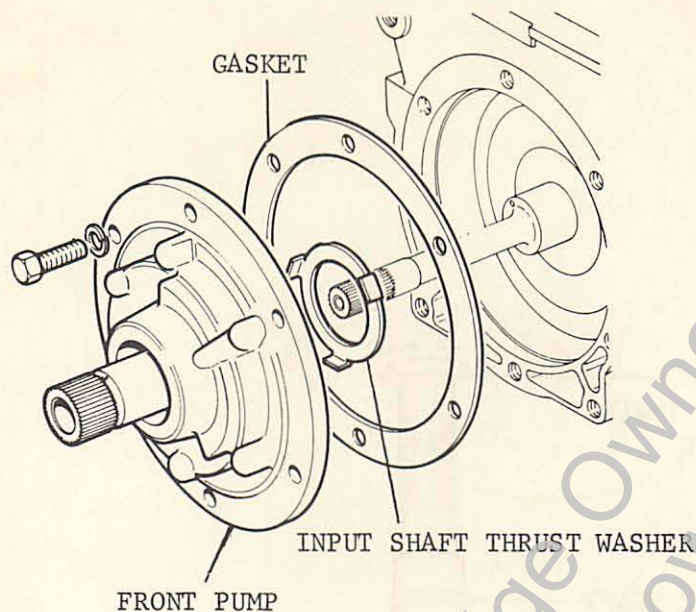

NOTE: This thrust washer is selective and determines amount of gear train end float. Two thrust washers of different thickness are available. Select one which will give .008" - .029" clearance.

10. Smear new oil pump gasket with grease, position gasket on oil pump.
11. Fit oil pump ensuring that stator tube is not displaced. DO NOT tighten oil pump securing bolts at this stage. Align marks.
12. Position new 'O' ring on oil pump inlet tube; smear 'O' ring with clean transmission fluid.
13. Fit oil pump inlet and outlet tubes; also convertor feed tube. Ensure tubes are correctly seated.



TOOL

14. Fit oil tube retaining plate; tighten bolts to a torque of 1.75 lbs. ft.

5/16" socket

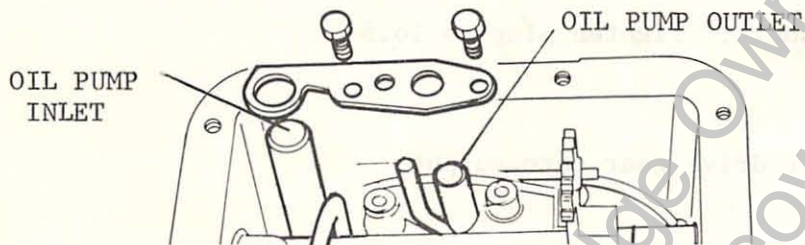

15. Tighten oil pump securing bolts by diagonal selection to a torque of 19 lbs. ft.
16. Fit governor feed tube, governor return tube and lubrication tube into transmission case; ensure tubes are correctly seated.

1/2" socket

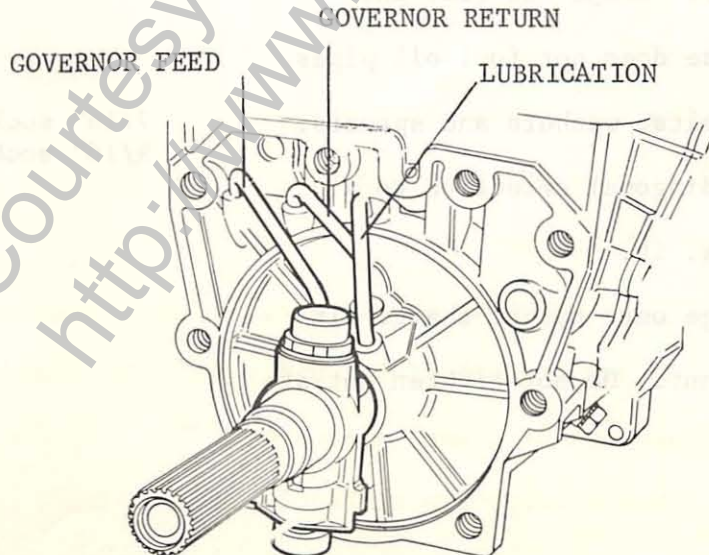

TOOL

CAUTION: Do not use undue force when pushing tubes into oil holes.

17. Slide governor onto output shaft, fit plug and spring washer, ensure plug enters BLIND hole in output shaft. Tighten plug to 16.5 lbs. ft. 1 1/8" socket
18. Slide speedometer drive gear onto output shaft.
19. Coat new oil seal with clean transmission fluid; press seal into recess in extension case. Ensure seal is correctly seated.
20. Smear new extension case gasket with grease; position gasket on extension case ensuring holes in gasket and case are in alignment.
21. Fit extension case ensuring that splines of output shaft do not damage oil seal and that extension case does not foul oil pipes.
22. Fit bolts, stud bolts, washers and spacers. Tighten bolts by diagonal selection to a torque of 2.5 lbs. ft. 7/16" socket  
9/16" socket
23. Slide output flange onto output shaft; fit plain washer and nut. Do not tighten nut at this stage.



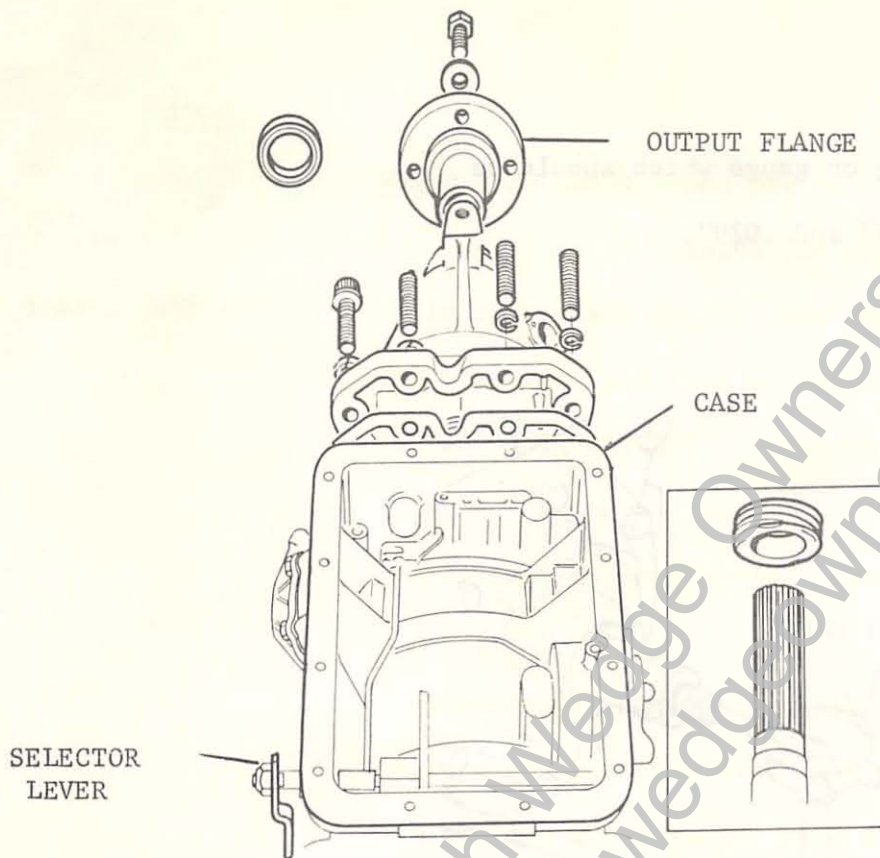

TOOL

- 24. Move selector lever until parking pawl engages with ring gear.
- 25. Tighten output flange securing bolt to a torque of 35 - 50 lbs. ft. 3/4" socket
- 26. Assemble end float gauge CBW.33 to gear case with stylus contacting end of input shaft. CBW.33  
Screwdriver
- 27. Insert a suitable lever between front clutch and front of gear case. Ease gear train to rear of gear case and zero end float gauge.
- 28. Insert lever between ring gear and rear clutch; ease gear train to front of gear case.

29. Note reading on gauge which should be between .008" and .029".

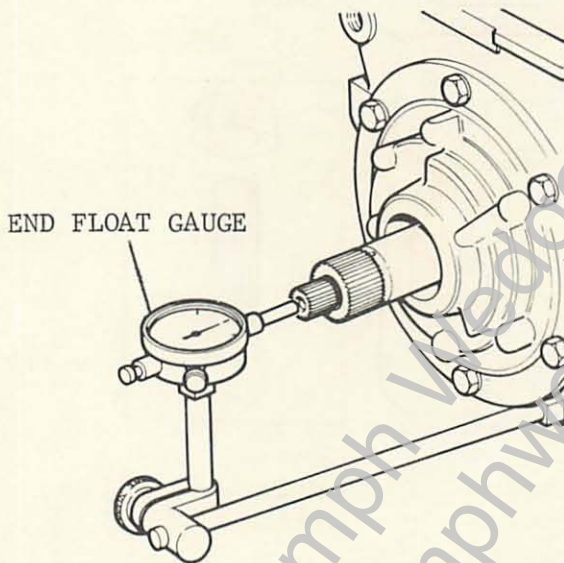

CAUTION: If end float exceeds .029", reverse operations 17 to 25 and 9 to 15. Fit alternative thrust washer and repeat operations 9 to 15 and 17 to 25.

30. Remove end float gauge.
31. Smear new 'O' ring with petroleum jelly, position 'O' ring in groove in speedometer driven gear shaft.



TOOL

32. Fit speedometer driven gear; ensure driven gear meshes with drive gear; do not over-tighten securing bolts.

7/16" socket

SPEEDO DRIVEN GEAR

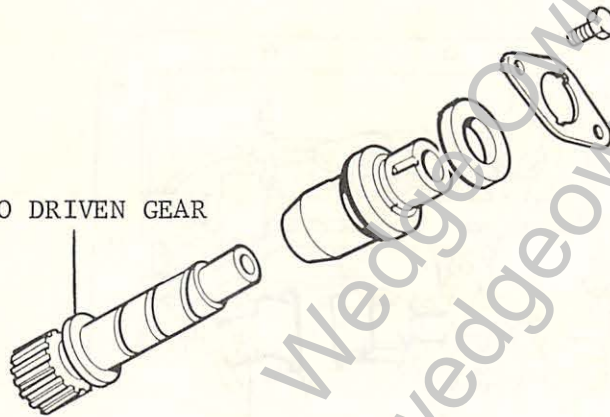

33. Smear new front servo gasket with grease; position gasket on servo body.

34. Fit front servo, spring and strut. Tighten bolts by diagonal selection to a torque of 19 lbs. ft.

1/2" socket

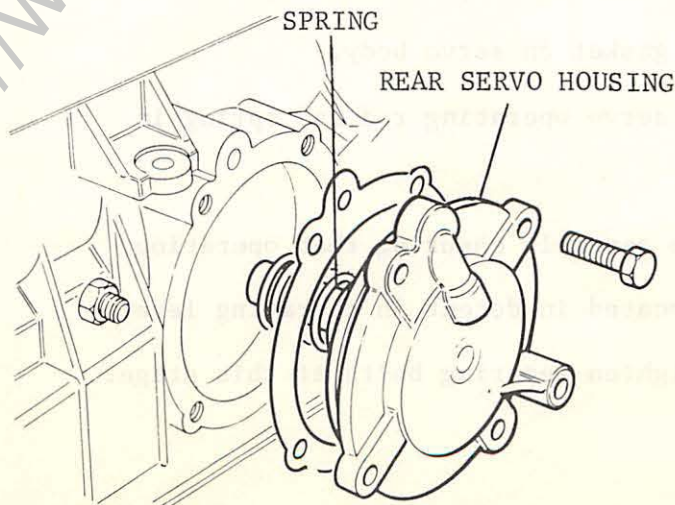

TOOL

35. Screw in front brake band adjusting screw until contact is made with brake band. Do not tighten locknut at this stage.

5/16" wrench

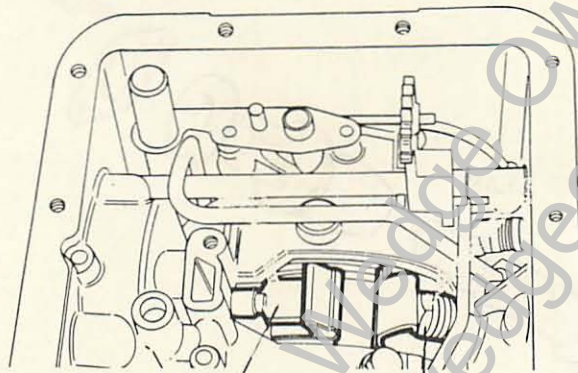

FRONT BRAKE  
BAND STRUT

ADJUSTING  
SCREW

36. Smear new 'O' rings with clean transmission oil; position 'O' rings in rear servo body oil holes.
37. Smear new rear servo gasket with grease, position gasket on servo body.
38. Position servo operating rod and spring in servo.
39. Fit servo assembly ensuring that operating rod is located in detent in operating lever. Do not tighten securing bolts at this stage.



TOOL

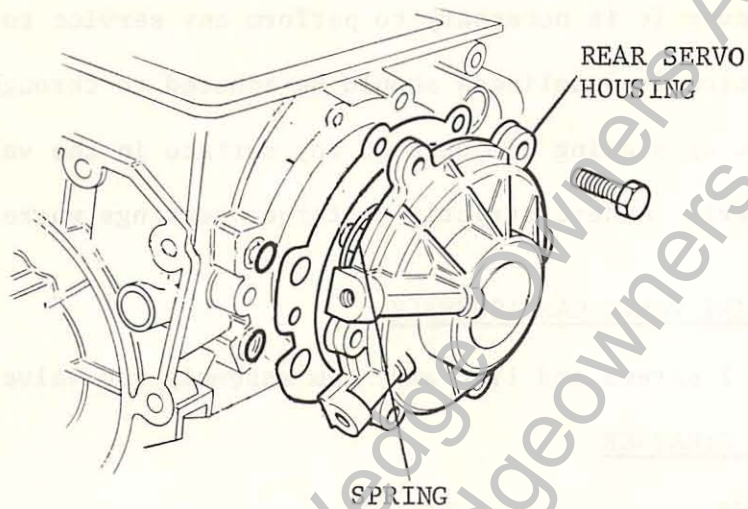

40. Position rear brake band strut in gear case; ensure brake band is correctly positioned.
41. Screw in rear brake band adjusting screw 5/16" wrench until contact is made with brake band. Do not over tighten locknut at this stage.
42. Tighten rear servo securing bolts by diagonal 1/2" socket selection to a torque of 19 lbs. ft.
43. Fit tube (converter to cooler). Do not use undue force.

## VALVE BODY

### VALVE BODY SERVICE

NOTE: Whenever it is necessary to perform any service to the valve body, exceptional cleanliness should be adhered to throughout. Never use a gasket or sealing compound on any surface in the valve body (except strainer). Adhere strictly to torque settings where indicated.

1. DOWNSHIFT VALVE CAM ASSEMBLY

Remove 2 screws and lift away cam assembly and valve.

2. REMOVE STRAINER

4 screws

3. REMOVE DETENT SPRING AND ROLLER

1 screw. Note spacer under spring.

4. UPPER VALVE BODY

Remove (4 screws) from top. Remove (6 screws) from below.

5. OIL TUBE COLLECTOR

Remove from below (8 screws). Tube location is fitted near to manual valve.

6. GOVERNOR LINE PLATE

Remove from top (4 screws) - note lengths.

7. SEPARATE COMPONENTS

Remove separator plate, convertor check valve and manual control valve.

8. DOWNSHIFT AND THROTTLE VALVE

Remove throttle valve stop and throttle valve return spring. Withdraw downshift and throttle valves. Remove throttle valve spring.



Throttle valve fits in with large land towards downshift valve.

9. MODULATOR VALVE

Remove the following parts from the large bore at side of lower valve body:

Dowel Pin - Modulator Valve

Plug - Modulator

Valve - Modulator (Large Land Faces Plug)

Spacer - Modulator Valve

Spring - Modulator Valve

10. SERVO ORIFICE CONTROL VALVE

Remove the following from the small bore at side of lower valve body:

Stop - Orifice Control Valve

Spring - Servo Orifice Control Valve

Valve - (Open End Faces Spring)

11. PRIMARY AND SECONDARY REGULATOR VALVES

From manual valve side of lower valve body remove (3 spring loaded screws) lower body end plate, primary regulator valve spring, primary regulator valve sleeve, primary regulator valve, secondary regulator valve spring and secondary regulator valve spring.

12. SHIFT VALVES

Remove the following from the upper portion of valve body (6 spring loaded screws):

Upper Body End Plate - Front

Upper Body End Plate - Rear

Remove from rear end of body:

2-3 Shift Valve

Spring 2-3 Shift Valve - Inner

1-2 Shift Valve (Large Land Faces End Plate)

Remove from front end of body:

Plunger 2-3 Shift Valve

Spring 1-2 Shift Valve

Plunger 1-2 Shift Valve (Open End Faces Spring)

Valve body is now dismantled for inspection. All parts, including valve blocks, should be thoroughly cleaned with proper solution and examined for wear. Any part thought to be the least suspect should be replaced.

Reassembly is reverse of dismantling procedures.



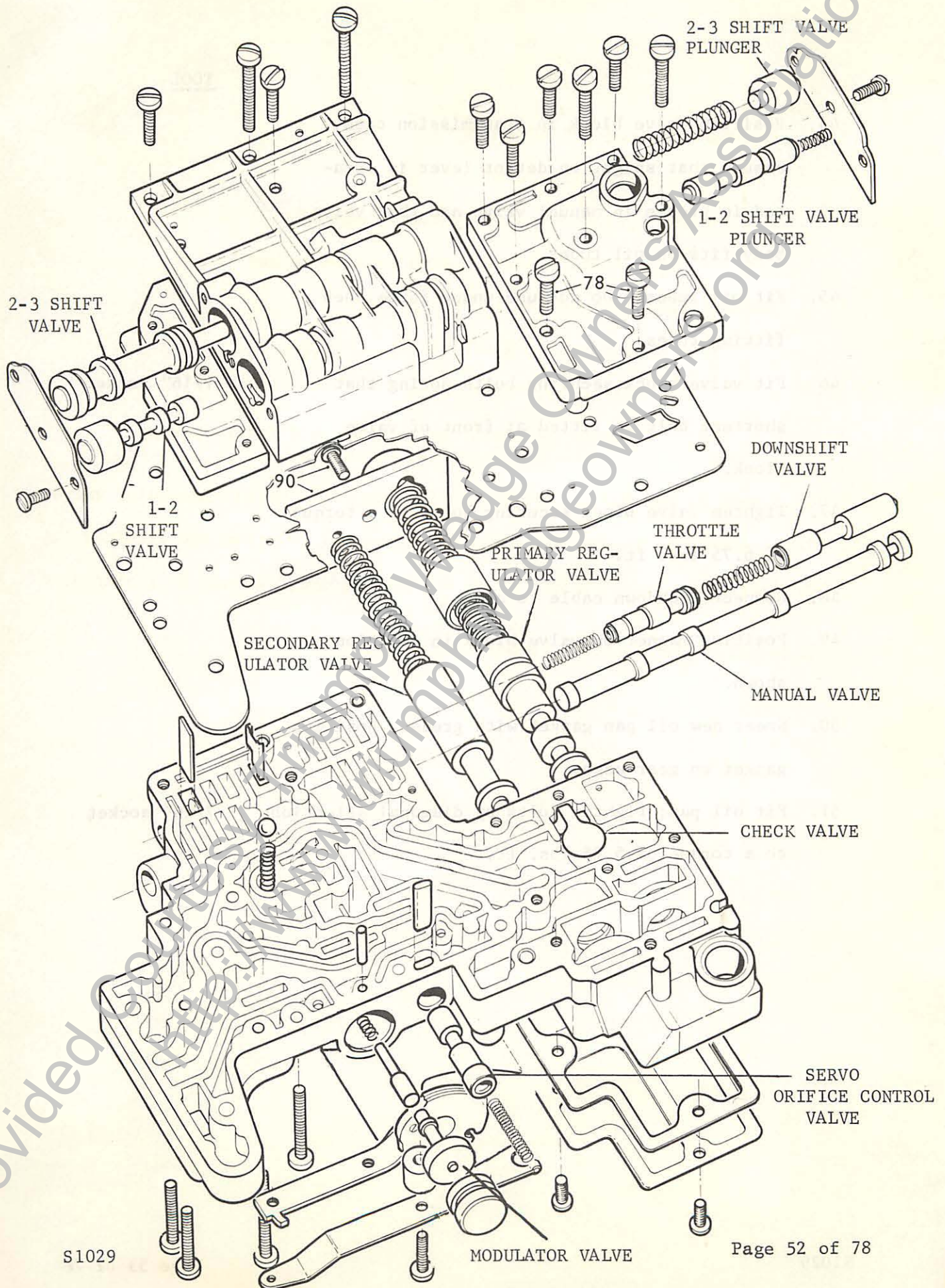



TOOL

44. Position valve block in transmission case, ensure that spigot on detent lever is located in groove in manual valve and that valve body fits on oil tubes.
45. Fit oil tubes. Do not use undue force when fitting tubes.
46. Fit valve block securing bolts noting that  $7/16$ " socket shortest bolt is fitted at front of valve block.
47. Tighten valve block securing bolts to a torque of 6.75 lbs. ft.
48. Connect kickdown cable to cam.
49. Position magnet on valve block in position shown.
50. Smear new oil pan gasket with grease; position gasket on gear case.
51. Fit oil pan; tighten bolts by diagonal selection  $7/16$ " socket to a torque of 5.75 lbs. ft.



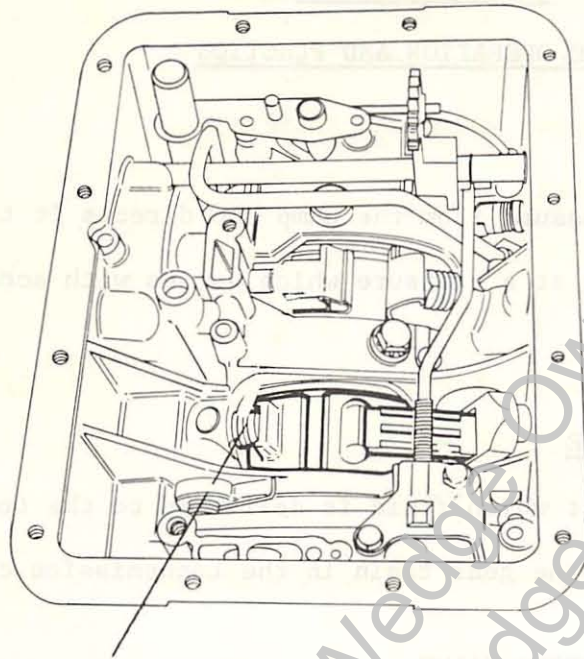

REAR BAND ADJUSTING SCREW

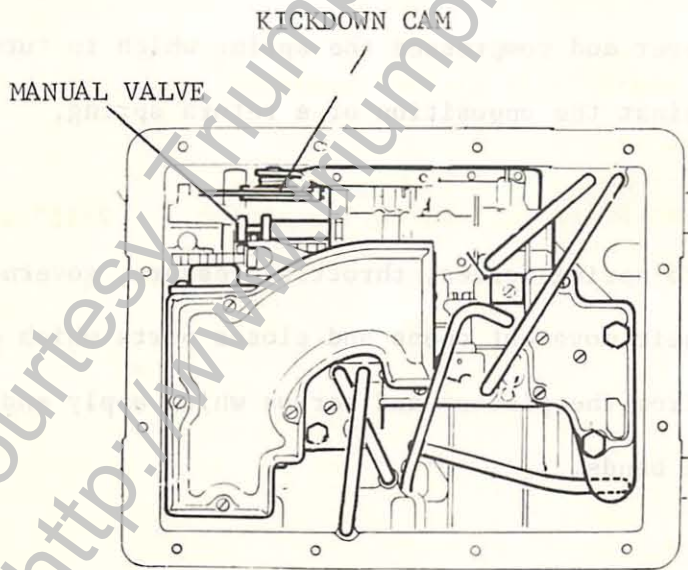

MANUAL VALVE

KICKDOWN CAM

## HYDRAULIC SYSTEM

### VALVE OPERATION AND FUNCTION

#### PRIMARY REGULATOR VALVE

Receives fluid under pressure from the pump and directs it to the manual valve and throttle valve at a pressure which varies with accelerator position and vehicle speed.

#### SECONDARY REGULATOR VALVE

Controls the pressures at which fluid is delivered to the torque convertor and (as a lubricant) to the gear train in the transmission case.

#### DOWNSHIFT VALVE AND THROTTLE VALVE

These valves are piston type valves arranged in tandem with a spring between them. The downshift valve is operated by a cable and cam from the carburetor throttle lever and compresses the spring which in turn moves the throttle valve against the opposition of a return spring.

#### SHIFT CONTROL VALVES

These valves respond to spring forces, throttle pressure, governor pressure and line pressure. Their movement opens and closes ports which control the flow of fluid to and from the pistons and servos which apply and release the clutches and brake bands.

#### MANUAL CONTROL VALVE

Directs fluid at line pressure to and from other valves and components according to the position of the gear selector.



#### SERVO ORIFICE CONTROL VALVE

A spring loaded shuttle valve in the front servo release circuit. It controls the rate of release by directing fluid through an orifice at higher governor pressure and bypassing the orifice at low governor pressure.

#### MODULATOR PLUG AND VALVE

The plug is a regulating valve that reduces throttle pressure by a fixed amount and directs the modulated pressure to the primary regulator valve. Along with this function, the stall pressure is also controlled.

#### GOVERNOR VERSUS THROTTLE PRESSURE

Controls shift points - Throttle position versus road speed.

NEUTRAL

With the engine running the FRONT PUMP draws oil from the sump (GREEN) and supplies oil to the primary regulator valve which regulates LINE PRESSURE (RED). Spill from the primary regulator supplies the torque convertor and lubrication requirements (RED-CROSS-HATCH). This supply is regulated by the secondary regulator valve.

The line pressure (RED) supplied to the manual and throttle valves, is blocked by lands on the valves so that neither governor, clutches or bands are applied.

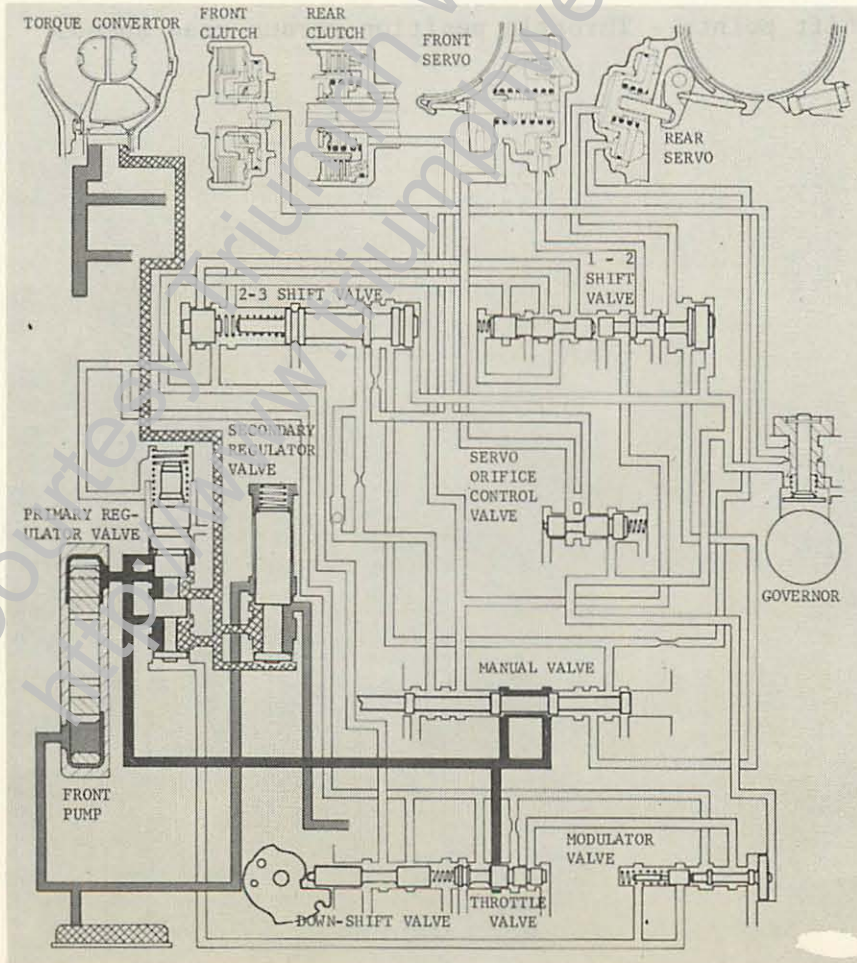



PARK

Coupled to the manual valve operating lever is linkage incorporating a pawl. Movement of this lever to the PARK position engages the pawl with the toothed ring gear, which locks the output shaft to the transmission case. The rear band is applied by line pressure (RED), but as both front and rear clutches are not applied and the park pawl is engaged, drive is not possible.

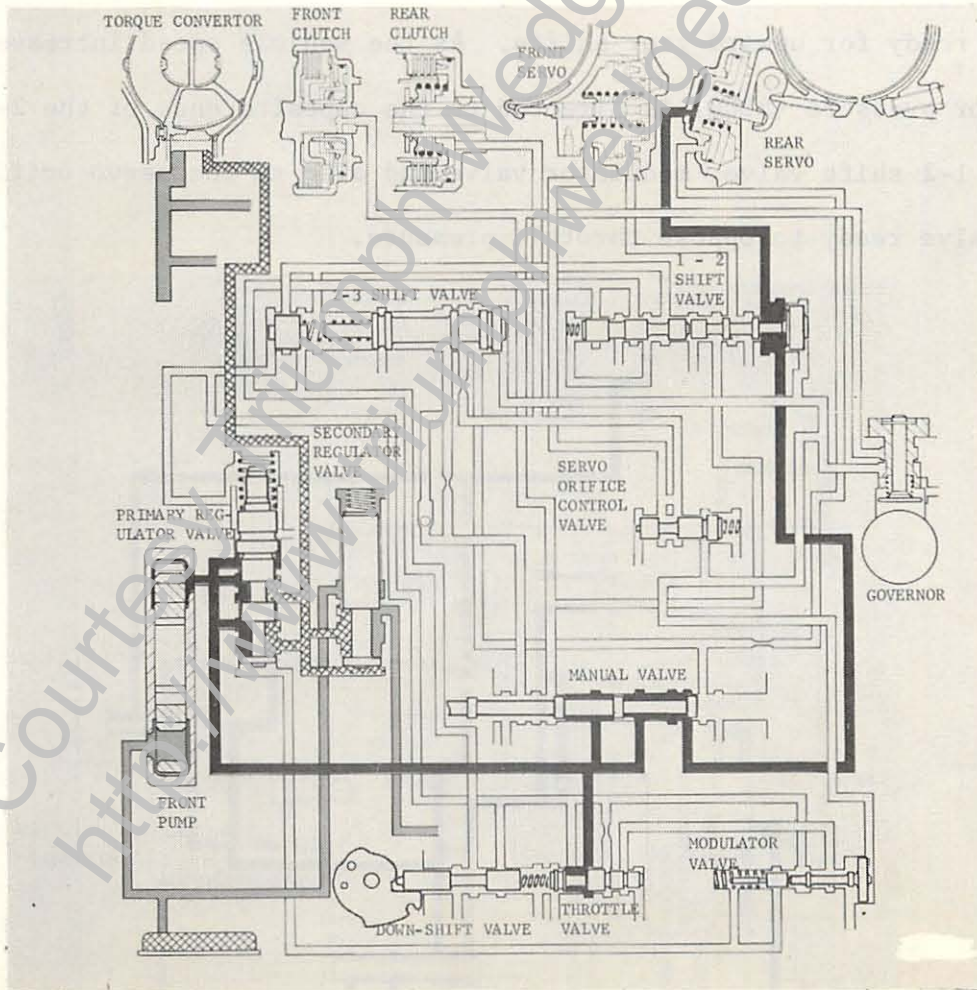

DRIVE 'D' (FIRST GEAR)

Throttle pressure (YELLOW) is applied to the spring end of the primary regulator valve. When the throttle valve is in the full throttle position, the modulator valve plug applies regulated throttle pressure (YELLOW) to the other end of the primary regulator valve, thereby controlling shift quality.

The manual valve directs line pressure (RED) to apply the front clutch, thereby enabling the vehicle to move off in first gear. The manual valve also directs line pressure (RED) to the governor feed and 1-2, 2-3 shift valves ready for upward gear shifts. As the vehicle speed increases, governor pressure (BLUE) is directed to the opposite ends of the 2-3 shift valve, 1-2 shift valve, modulator valve and also to the servo orifice control valve ready to oppose throttle pressure.

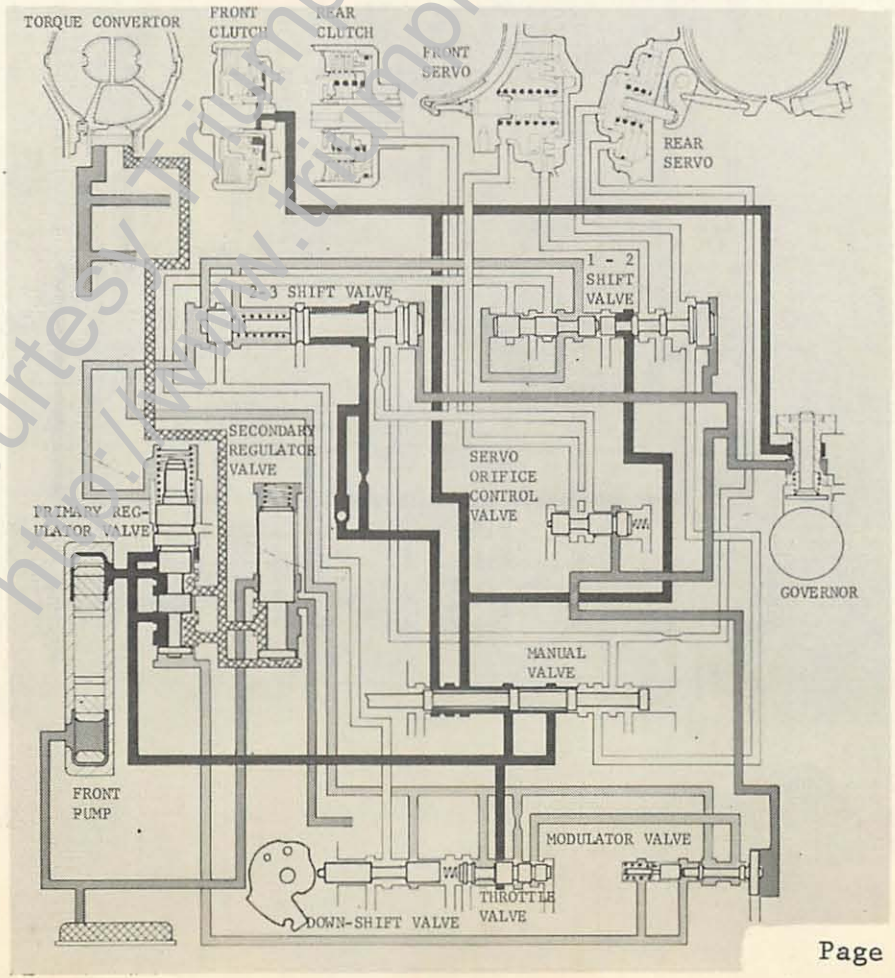



DRIVE 'D' (SECOND GEAR)

Pressure control by the primary regulator valve functions as described in 'D' (first gear).

When governor pressure (BLUE) exceeds throttle pressure (YELLOW), the 1-2 shift valve moves and directs line pressure (RED) to the front servo which applies the front band. As the front clutch is applied, the transmission operates in second gear.

When the downshift valve is in the forced throttle (kickdown) position, forced throttle pressure (YELLOW) acts upon the 1-2 and 2-3 shift valve, thereby delaying upshift or, if governor pressure (BLUE) is low, causes a 2-1 downshift.

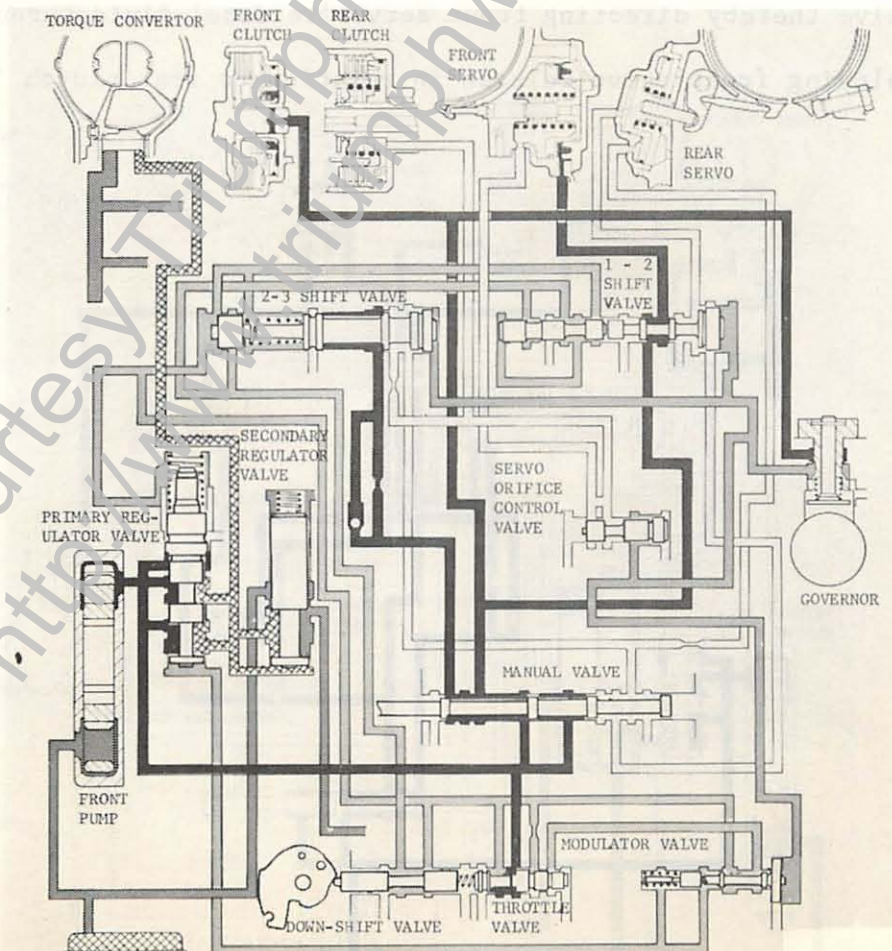



DRIVE 'D' (THIRD GEAR)

Line pressure control by primary regulator valve functions as described in 'D' (first gear). 2-3 shift occurs early at light throttle or late at full throttle depending upon pressure balance between governor and throttle pressures. When governor pressure exceeds throttle pressure, 2-3 shift valve directs line pressure (RED) to rear clutch and also to RELEASE side of front servo via servo orifice control valve. This pressure, being higher than that acting upon 'apply' side, causes the front servo to release front band.

The timed relationship between rear clutch 'apply' and front servo 'release' is dependent on governor pressure (BLUE) which in turn is controlled by engine speed. A high governor pressure (BLUE) closes servo orifice control valve thereby directing front servo 'release' fluid through a restrictor, thus delaying front servo release in relation to rear clutch 'apply'.

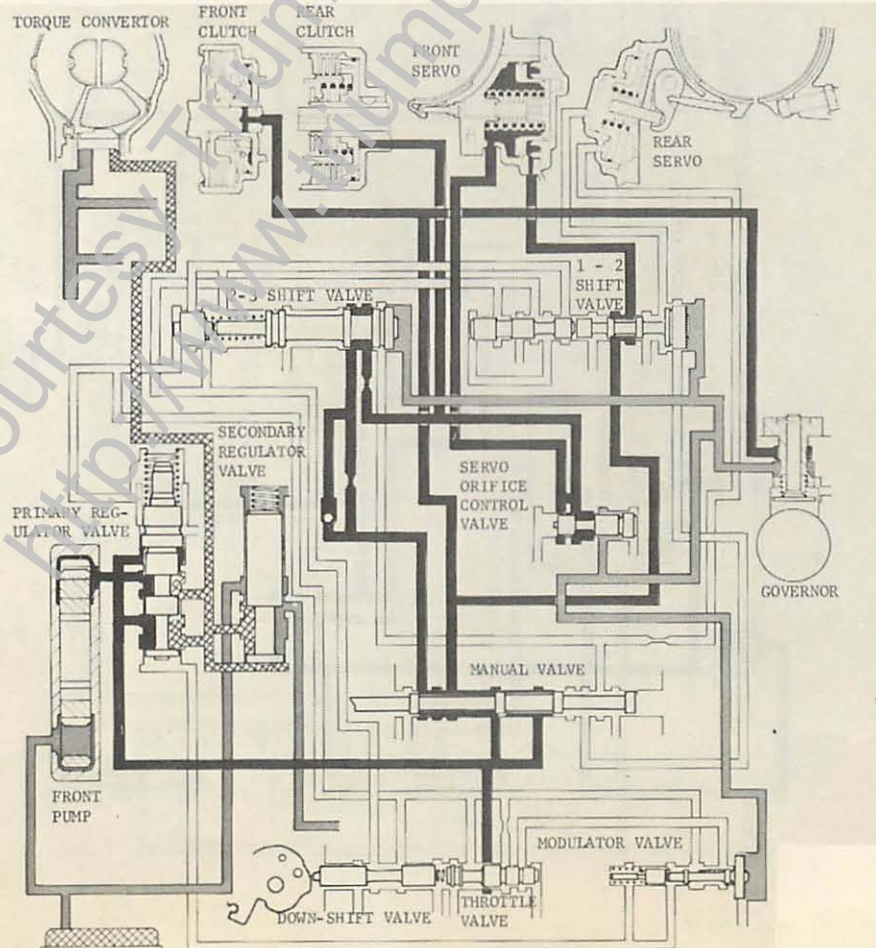



'2' (LOW GEAR)

Line pressure (RED) control by primary regulator valve functions as described in 'D' (first gear). Front clutch is applied, but as engine speed is low, governor pressure (BLUE) causes 1-2 shift valve to remain closed, thereby blocking feed from modulator valve.

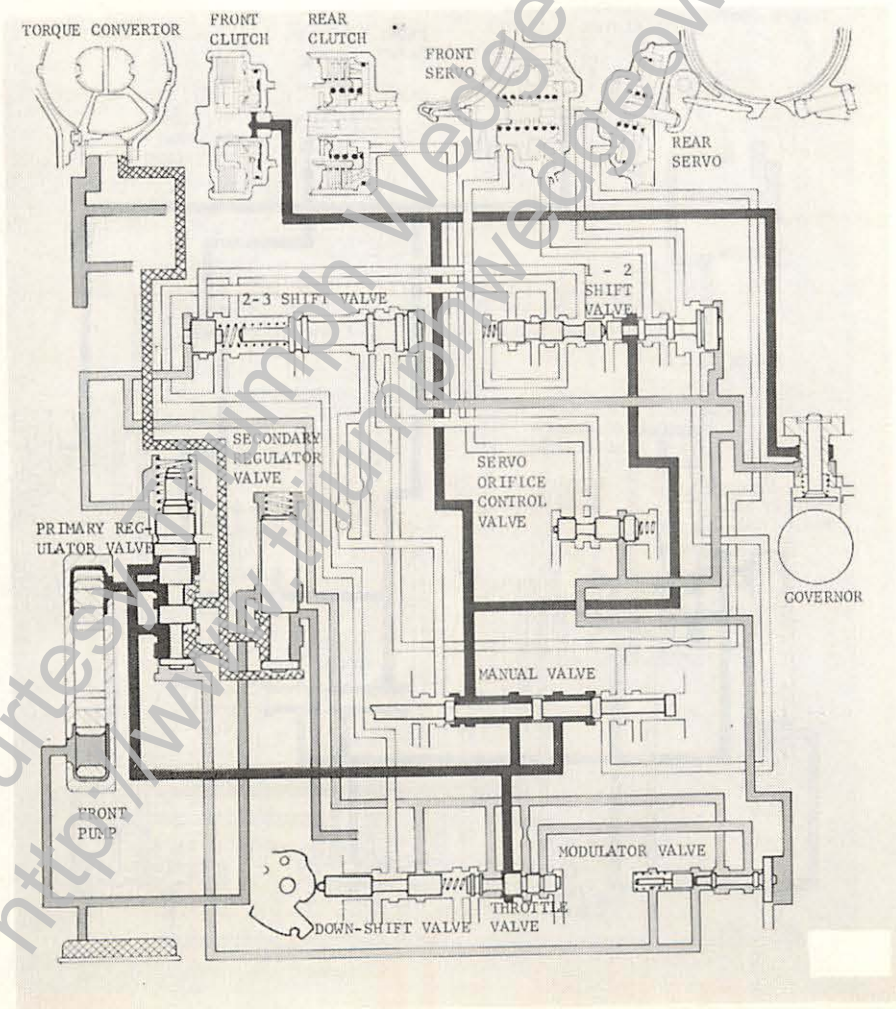

'2' (SECOND GEAR)

Front clutch is still applied and as engine speed increases, governor pressure (BLUE) rises and moves 1-2 shift valve. This allows pressure from modulator valve to apply front servo.

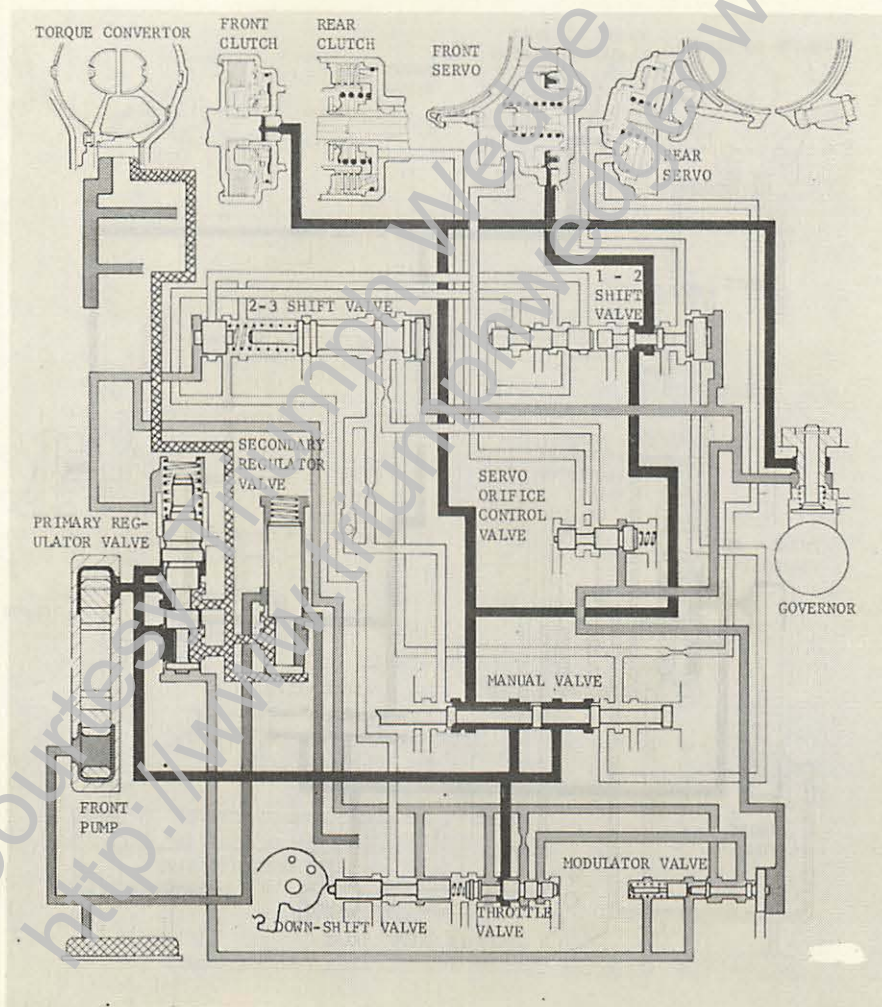



'1' (LOW GEAR)

Line pressure (RED) control by primary regulator valve functions as described in 'D' (first gear).

Manual valve directs line pressure (RED) to front clutch, governor feed and 1-2 shift valve. Pressure is also directed to enlarged end of 1-2 shift valve so that opposing governor pressure (BLUE) and line pressure (RED) hydraulically 'locks' the valve. Rear servo is also applied and no upshifts can occur.

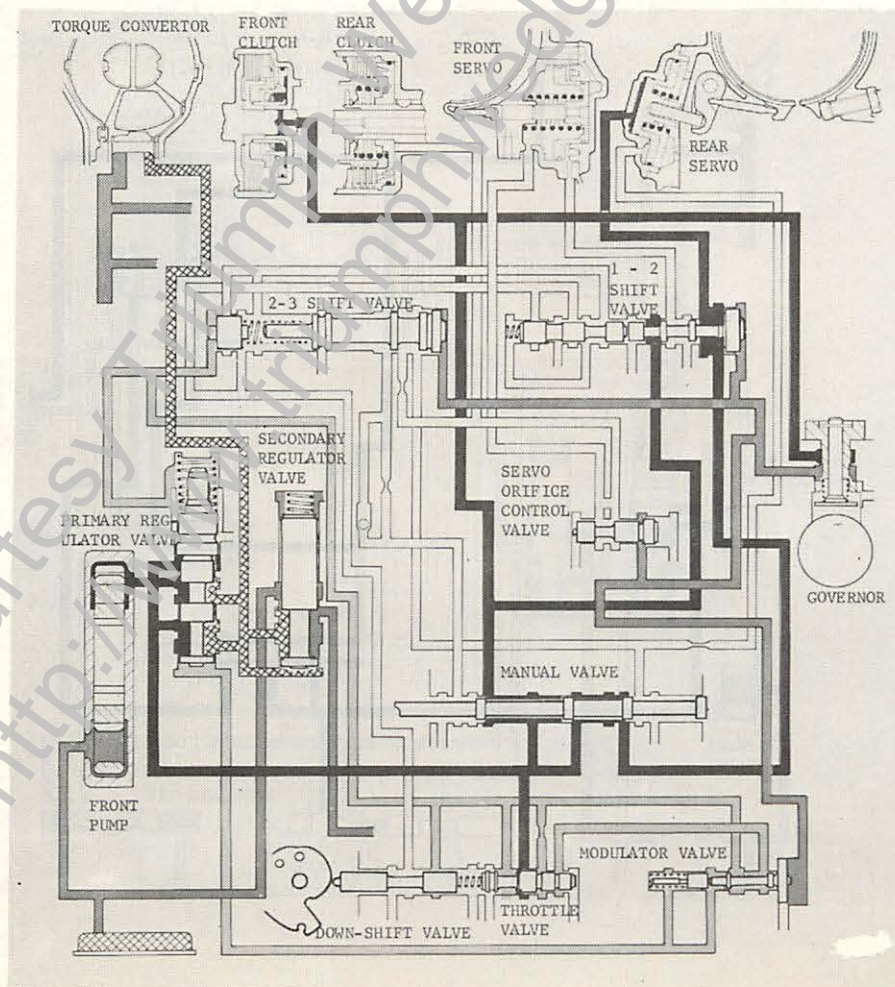



'1' (SECOND GEAR)

When the selector lever is moved to position '1' at speed, the rear servo is released and a downshift from high to intermediate gear occurs. As governor pressure (BLUE) has operated 1-2 shift valve, line pressure (RED) which was blocked from rear servo, is directed to 'apply' side of front servo. A further downshift to low gear occurs when vehicle speed falls sufficiently.

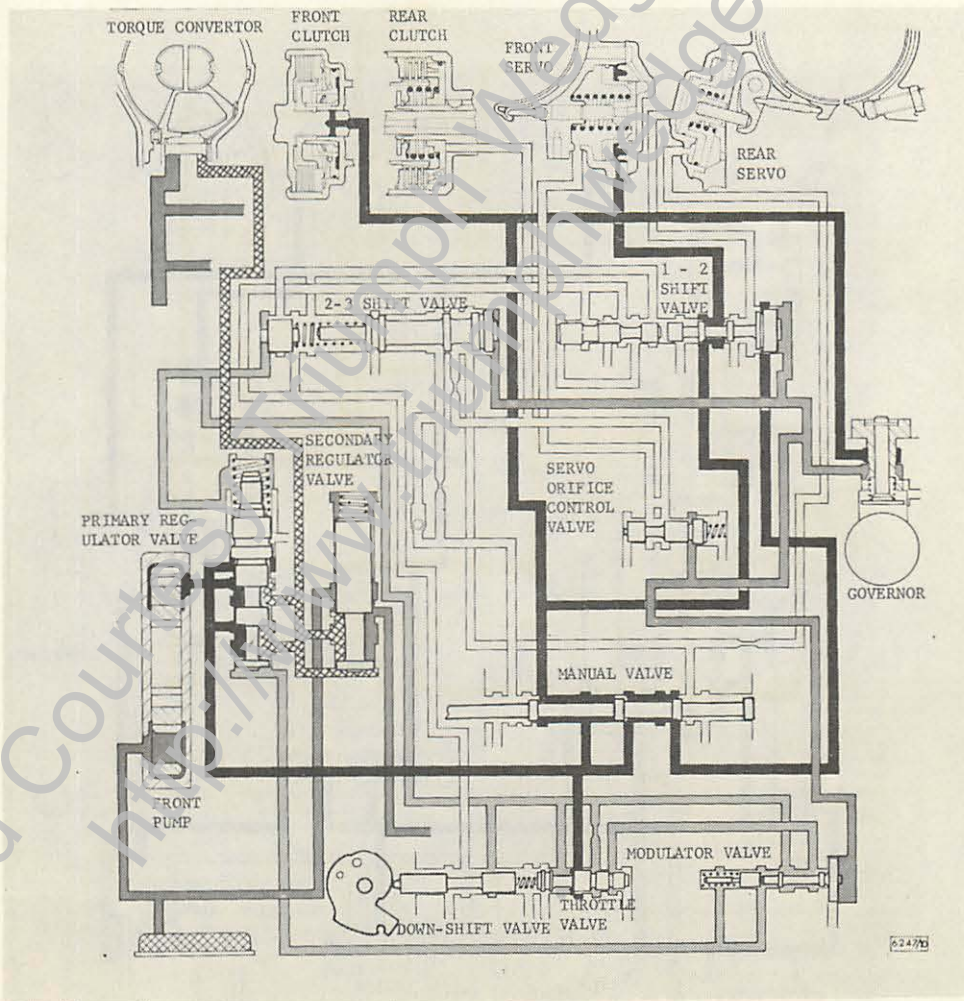



'R' (REVERSE)

Throttle pressure (YELLOW) applied to spring end of primary regulator valve increases line pressure (RED) proportionally to engine output. Manual valve directs line pressure (RED) through 1-2 shift valve to apply rear servo and through 2-3 shift valve to release front servo and apply rear clutch.

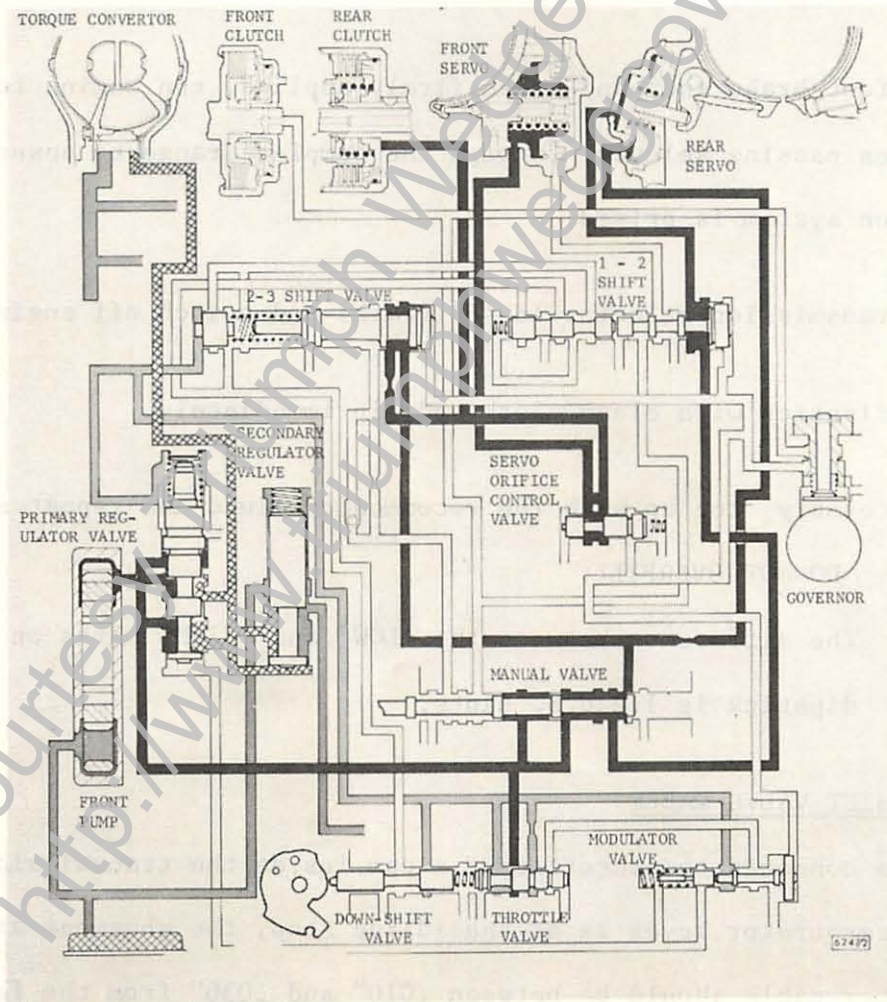

## MAINTENANCE AND ADJUSTMENT PROCEDURE

### CHECKING FLUID LEVEL

When checking fluid level or topping up, extreme care must be taken to prevent the entry of dust or other matter into the transmission filler tube.

Checking fluid level should be carried out with the vehicle on a level surface. The procedure is then as follows:

1. With foot-brake and hand-brake firmly applied, run engine for several minutes passing selector through the complete range to ensure transmission system is primed.
2. Put transmission selector in 'P' (Park) and switch off engine.
3. Wipe dipstick with clean cloth and dip immediately.
4. If necessary, top up with the recommended fluid and repeat steps 1 - 4. DO NOT OVERFILL.

NOTE: The difference between the 'LOW' and 'HIGH' marks on the dipstick is 1.2 U.S. pints.

### THE DOWNSHIFT VALVE CABLE

This cable connects the throttle to a cam inside the transmission housing. When the carburetor lever is at the idling stop, the abutment at the end of the outer cable should be between .010" and .030" from the ferrule which is crimped to the exposed part of the inner cable, adjacent to the



carburetor.

To check for proper adjustment you need an engine tachometer and line pressure gauge. An increase in engine speed from idle with the selector in 'D' (brakes applied), should cause a rise in line pressure. Increasing the effective length of the outer cable will cause a rise of pressure. Decreasing the length will cause a drop in pressure.

#### DOWNSHIFT CABLE ADJUSTMENT

1. Check engine tune, i.e., cylinder compressions, spark plugs, ignition timing, carburetors.
2. Lift carpet from left-hand side of transmission tunnel.
3. Remove screws securing access plate; withdraw plate.
4. Clean any traces of sealing compound off access plate and transmission tunnel.
5. Using a suitable Allen key, remove blanking plug from gear case.  
CAUTION: On later cars, a bracket is fitted between gearbox and rear mounting. Access to blanking plug is through hole in bracket and under no circumstances may bracket be removed.
6. Connect pressure gauge to gearbox using appropriate adaptor.  
CAUTION: Do not over tighten adaptor.
7. Feed gauge and hose through aperture in transmission tunnel ensuring that hose is kept clear of exhaust pipe.
8. Run engine until it reaches normal operating temperature.
9. Chock wheels and apply hand and foot brakes.
10. Select 'D'; pressure gauge should read 60 - 75 p.s.i. at idling speed.

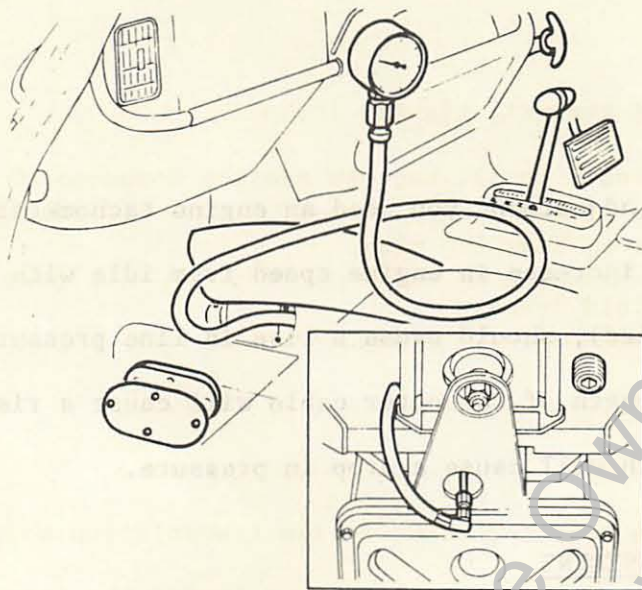

11. Increase engine speed to 1200 r.p.m., gauge should read 85 - 95 p.s.i.

If above readings are not obtained, proceed as follows:

**WARNING:** ENGINE MUST BE SWITCHED OFF AND SELECTOR LEVER IN 'N' BEFORE CARRYING OUT ADJUSTMENT.

12. Slacken locknut on downshift cable.

13. By means of abutment nut on outer cable, adjust length of cable to alter pressure.

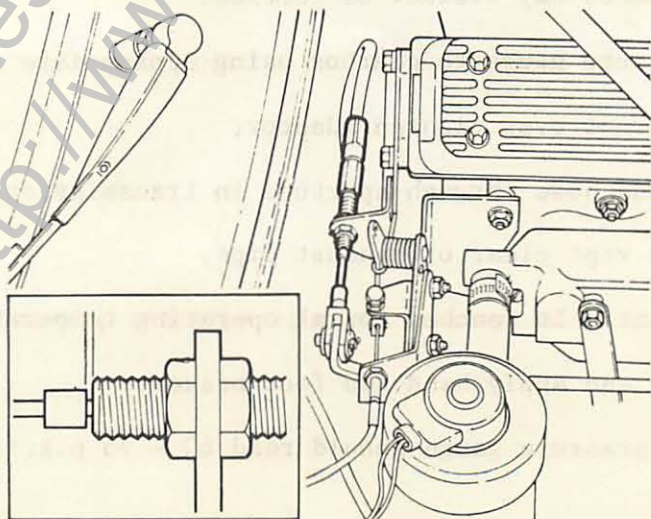



14. When pressure is correct, tighten locknut.
15. Reverse operations 2 to 11, use new sealing compound on access plate; do not over tighten blanking plug.
16. Check gearbox fluid level.
17. Road test car.

#### MANUAL SHIFT ROD

This rod connects the selector lever to the transmission shift lever. The adjustment should be made so that the detent inside the transmission case engages with a positive 'click' when checked in each of the six positions of the selector lever. The selector lever and gate must never override the detent.

#### GEAR SELECTOR CABLE ADJUSTMENT

1. Remove console.
2. Place quadrant selector lever in '1'.
3. Unscrew gear selector knob.
4. Remove screws securing selector indicator; withdraw indicator over selector lever.
5. Remove split pin and washer securing cable to selector lever; detach cable.

#### Refitting

6. Ensure gearbox selector and quadrant selector levers are in '1'.

7. Adjust front and rear locknuts until cable can be connected to quadrant lever without either quadrant or gearbox lever being disturbed.
8. Tighten locknuts, secure cable with new split pin.
9. Reverse operations 1 to 4.

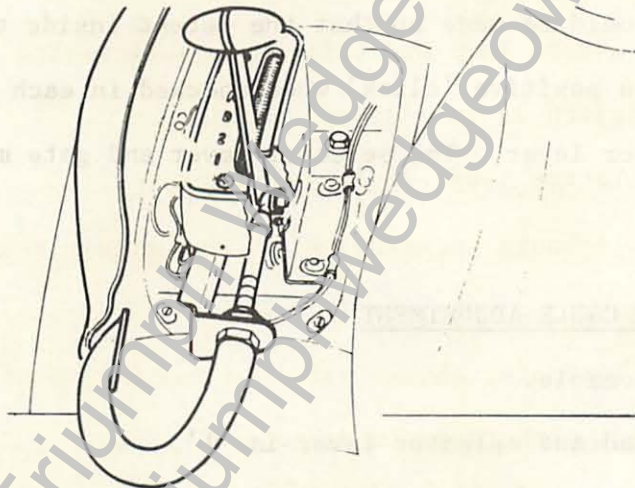

THE INHIBITOR SWITCH - (NEUTRAL SAFETY SWITCH)

This is a two function switch. One pair of wires, when joined, should make the starter operable. The second pair, when joined, should make the reverse lights operate.

STARTER INHIBITOR SWITCH - CHECK AND ADJUST

1. Disconnect battery.
2. Unscrew gear selector knob.



3. Remove screws securing selector indicator; withdraw indicator over selector lever.
4. Carefully prize electric window switch panel away from center console; do not disconnect window switches.
5. Remove screws securing control escutcheon; withdraw escutcheon slightly to obtain access to cigar lighter and door lock switch terminals.
6. Note fitted position of cigar lighter and door lock switch terminals; detach terminals and withdraw escutcheon.
7. Detach feed cable from inhibitor switch.
8. Connect a test lamp and battery in series with switch.  
NOTE: Switch is in earthed position.
9. Place selector lever in 'N' position.
10. Slacken locknuts securing switch and adjust position of switch until lamp lights.
11. Tighten locknuts, check that lamp remains on with lever in 'P' position and is off with lever in drive position.
12. Remove battery and test lamp, reconnect feed cable to switch.
13. Reverse operations 1 to 6.
14. Check operation of window switches, door lock switch and cigar lighter.

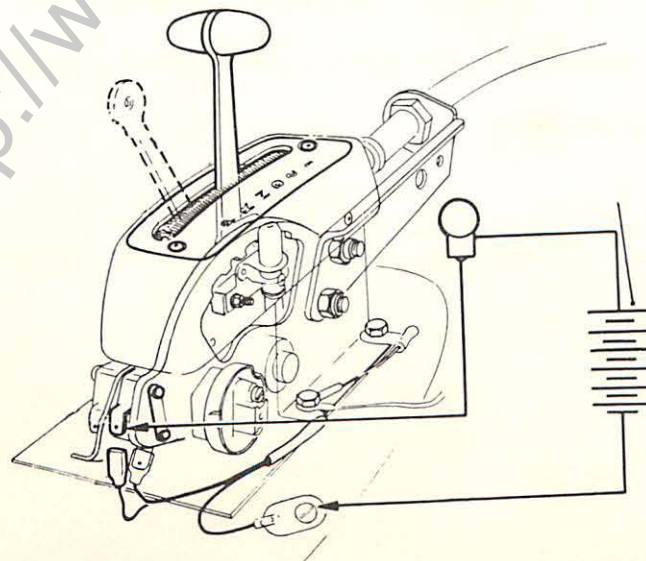

### THE BRAKE BANDS

Each band has an external adjusting screw on the side of the transmission case opposite to the corresponding servo. In each case, adjust by slackening the lock nut and then tightening the adjusting screw using a torque wrench with suitable socket. Tighten both the front and rear bands to a torque of 5 lb.ft., then back off  $3/4$  of a turn. Retighten lock nuts to correct torque settings taking care not to disturb the adjustment.

### STALL PRESSURE TEST

Ensure that both foot-brake and hand-brake are firmly applied. Chock wheels. Start engine, engage 'D' (Drive) and accelerate to full throttle. Engine speed should be between 1,950 and 2,100 r.p.m. at full stall.





## ROAD TEST PROCEDURES

The following points should be checked before proceeding with the road test:

1. FLUID LEVEL
2. ENGINE IDLE SPEED
3. MANUAL LEVER ADJUSTMENT

### ROAD TEST

Road testing should follow the complete sequence detailed below. Transmission should be at normal working temperature, i.e. after being driven on road or dynamometer.

1. With brakes applied and engine idling, move selector from:

'N' to 'R'

'N' to 'D'

'N' to '2'

'N' to '1'

Engagement should be felt with each selection.

2. Check stall speed.
3. Select 'D', accelerate with minimum throttle opening and check speed of first gear to second gear shift.
4. Continue with minimum throttle and check speed of second gear to third gear shift.
5. Select 'D', accelerate with maximum throttle opening (kickdown) and check speed of first gear to second gear shift.
6. Continue with maximum throttle and check speed of second gear to third gear shift.

7. Check for kickdown shift third gear to second gear.
8. Check for kickdown shift second gear to first gear.
9. Check for kickdown shift third gear to first gear.
10. Check for 'roll-out' downshift with minimum throttle, second gear to first gear.
11. Check for part throttle downshift, third gear to second gear.

Should a fault be apparent during road test, first identify the problem from the list printed in the Fault Diagnosis Chart. The reference numbers shown opposite each fault may be translated by reference to the page headed 'Transmission Fault Key'.

---

#### FAULT DIAGNOSIS

---

##### STATIONARY TEST FINDINGS

##### ACTION

Starter will not operate in 'P' or 'N' or operates in all positions.	22
Faulty operation of reverse lights	22
Excessive bump on engagement of 'D', '1' and 'R'	3,4
Drives in 'N' also giving judder or no drive in 'R' depending on degree of front clutch seizure	9

##### STALL TEST FINDINGS

Stall test shows over 2,100 rpm (transmission slip), with possible squawk in '1' and 'R'	4
a. only in '1'	9
b. only in 'R'	6,8,10,21,15
Stall test shows under 1,300 rpm (slipping stator)	20

##### DRIVING TEST FINDINGS

##### SELECTION FAULTS

Incorrect selection of all positions except 'P'	2
Parking pawl does not hold vehicle	16



	ACTION
<b>RATIO FAULTS</b>	
No drive in 'D', '2', '1' or 'R' but 'P' operates	1,2,4
No drive in 'D', '2' or '1'	12,13,9
No drive in 'D' 1st ratio	17
No drive in '1' and transmission binding during shift from '1' to 'D'	23
No second ratio	5,7,11
No D3 (Reverse indicating rear clutch normal)	11
Drag in 'D'	6
Drag in 'D', '1' and reverse	5
No engine braking in '1' and no drive in reverse ratio	6,8,15
Moves off in 2nd ratio in 'D' and '1' and no drive in reverse or engine braking in '1'	11
<b>SHIFT POINT FAULTS</b>	
Incorrect or erratic 'kick-down' and/or light throttle shift points	4,12,13
1-2 shift only incorrect	11
2-3 shift only incorrect	11
No up-shifts	12,13
Lack of 'up-shifts' and no reverse ratio	11
Moves off with possible transmission slip	12
Reduced maximum speed in all ratios, more so in 'D', and severe convertor overheating	20
<b>SHIFT QUALITY FAULTS</b>	
Bumpy and possibly delayed shifts	4
Slip (engine 'flare-up') shifting into and out of second ratio	5,7,11,14
Slip (engine 'flare-up') on 2-3 and 3-2 shifts	10,11,21
<b>NOISE FAULTS</b>	
Whining noise from convertor area, continuous whenever the engine is running	18
Irregular (possibly grating) noises from gearbox but not in 'D'	19
Whine from convertor for short period following engine starting after vehicle has been standing for, say, not less than 12 hours.	24

TRANSMISSION FAULT KEY

ACTIONS

1. Check fluid level.
2. Check manual selector/adjustment.
3. Reduce engine idle speed.
4. Check down-shift throttle cable/adjustment.  
If pressure cannot be corrected, dismantle and clean valve bodies. For low pressure also check strainer, alloy suction pipe, 'O' ring and pump.
5. Check front brake band adjustment.
6. Check rear brake band adjustment.
7. Check front servo seals and fit of pipes.
8. Check rear servo seals and fit of pipe.
9. Examine front clutch, support housing and primary sun gear shaft seals.
10. Check rear clutch feed pipe.
11. Strip valve bodies and clean.
12. Strip governor valve and clean.
13. Examine output shaft rings and governor pressure tube seals.
14. Check front brake band for wear.
15. Check rear brake band for wear.
16. Adjust/examine parking pawl, linkage and gear.
17. Renew one-way clutch.
18. Examine pump gears and convertor nose bush.
19. Strip and examine gear train.
20. Replace torque convertor.
21. Examine rear clutch and sealing rings.



(Transmission Key Fault Continued)

ACTIONS

- 22. Test inhibitor switch, circuit and check for operation.
- 23. Check one-way clutch (possibly fitted backwards).
- 24. Converter valve faulty, no detriment to performance.

GEAR CHANGE SPEEDS

THROTTLE POSITION

UPSHIFTS

DOWNSHIFTS

	UPSHIFTS		DOWNSHIFTS	
	1 to 2	2 to 3	3 to 2	3 to 1
Minimum . . . . .	8 - 12	13 - 18		
Full . . . . .	41 - 51	73 - 81		
Full Throttle Kickdown . . . . .			63 - 73	25 - 35
Closed Throttle Downshift (Roll Out)				5 - 10
Part Throttle Kickdown . . . . .			32 - 42	

M.P.H.

NOTE: The figures in this table are theoretical and actual figures may vary slightly from those quoted due to such factors as tire wear, pressures, etc.