



TRIUMPH
SLANT 4 ENGINES

1854cc and 1998cc

Provided Courtesy Triumph Wedge Owners Association
<http://www.triumphwedgeowners.org>

Provided Courtesy Triumph Wedge Owners Association
<http://www.triumphwedgeowners.org>



Provided Courtesy Triumph Wedge Owners Association
<http://www.triumphwedgeowners.org>

CYLINDER HEAD

The following is the head tightening sequence when the latest head gasket is fitted.

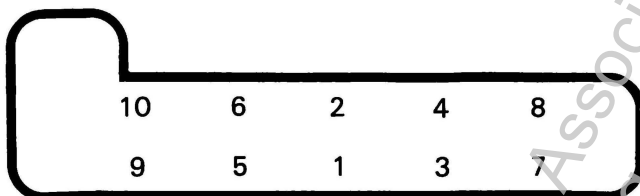

When phosphated cylinder head studs and bolts are fitted the cylinder head should be tightened to 45 to 50 lbf ft (6.2 to 7.6 kgf. m).

The maximum figure must not be exceeded.

WATER PUMP

To improve coolant flow a new 12 bladed water pump impeller and cover have been fitted on production to all engine variants.

These new parts are interchangeable with the former six bladed impeller and cover as a set only.

COOLING SYSTEM TOP UP/REFILL

The following procedure is provided to ensure complete filling of the TR7, Dolomite and Sprint models engine cooling system during refill or topping up operations. However, it is essential to check that all hose clips and joints are completely air tight.

1. Check and if necessary half fill cooling system expansion tank, situated at right hand front side of engine compartment, with correct solution of anti-freeze.
2. Refit expansion tank pressure cap.
3. Set interior heater controls to maximum heat position.
4. Remove filler plug from top of thermostat housing and fill system to bottom of filler plug threads in housing with correct solution of anti-freeze.
5. Refit filler plug carefully, do not overtighten.
6. Remove pressure cap from expansion tank.
7. Run engine for three minutes at approximately 1200 R.P.M.
8. Stop engine.
9. Refit expansion tank pressure cap.
10. Remove filler plug from thermostat housing.
11. Gently squeeze large top hose between thermostat housing and radiator to expel any trapped air in hose.
12. Top up system to bottom of filler plug threads in thermostat housing.
13. Refit filler plug using new sealing washer if necessary. Do not overtighten.
14. Recheck expansion tank coolant level and top up to half full if necessary.

Note that in the event of coolant loss due to leakage in use, the temperature gauge reading will initially rise to danger and then drop back once the transmitter is no longer covered by water. If the car is driven in this condition, serious damage will occur.

16 VALVE ENGINE

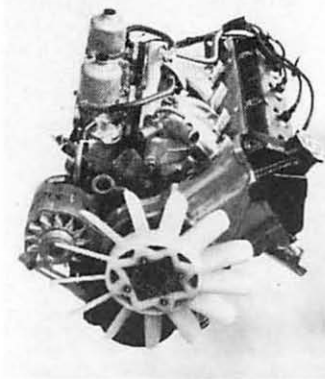

SLANT 4 ENGINE

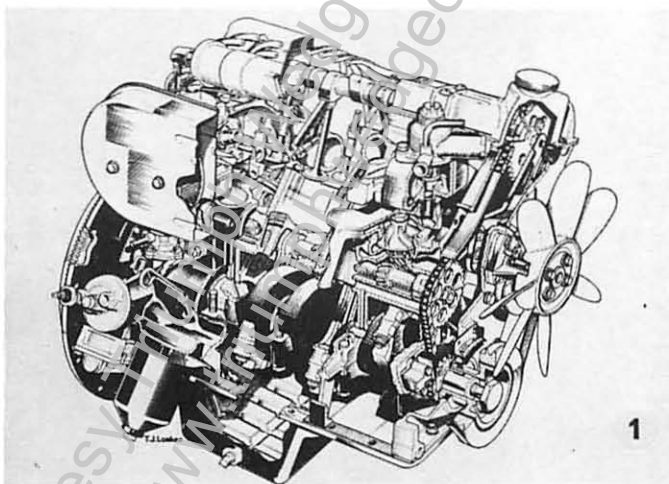
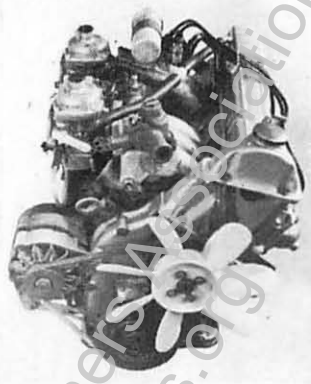

INTRODUCTION

This booklet and the accompanying filmstrip show the main features of the Triumph Slant 4 Cylinder Engine and the 16 valve version.

MAIN SECTIONS

- Part 1 Cylinder Head Removal and Overhaul
- Part 2 Lubrication
- Part 3 Crankcase Ventilation
- Part 4 Crankshaft and Assemblies
- Part 5 Fitting the cylinder head
- Part 6 Thermostat and Cooling System
- Part 7 Carburetter and Petrol Pump
- Part 8 Fan Viscous Coupling
- Part 9 Distributor
- Part 10 Exhaust Manifolds
- Part 11 Water Pump Removal and Overhaul

It is intended that the filmstrip should form the basis of a lecture. The subject matter can be elaborated or abbreviated to suit the type of audience. The booklet itself provides a handy pocket manual for ready reference.

FRAME 1

The illustration of the Triumph Slant 4 Cylinder Engine above shows the location of the major components.

TECHNICAL DATA

The engine is an in-line four-cylinder slant configuration which is naturally aspirated, is water-cooled, and has a wet sump lubrication system.

Capacity	1854 cc (113.2 cu in)
Bore	3.452 in (87 mm)
Stroke	3.071 in (78 mm)
Compression ratio	9.0 : 1
Maximum power	91 b.h.p. at 5,200 rev/min
Maximum torque	105 lbf ft at 3,500 rev/min
Firing order	1, 3, 4, 2
Engine Commission No. Prefix	WF1HE and upwards

FRAME 2

The illustration of the Triumph Slant 4 Cylinder 16 valve engine above shows the location of the major components.

TECHNICAL DATA

The engine is an in-line four-cylinder slant configuration which is naturally aspirated, is water-cooled, and has a wet sump lubrication system.

Capacity	1998 cc (122 cu in)
Bore	3.56 in (90.3 mm)
Stroke	3.071 in (78 mm)
Compression ratio	9.5 : 1
Maximum power—net	127 b.h.p. at 5,700 rev/min
Maximum torque—net	1,465 lbf in at 4,500 rev/min
Firing order	1, 3, 4, 2
Engine Commission No. Prefix	VA1HE onwards

FRAME 3

PART 1

CYLINDER HEAD—SERVICE REMOVAL

NOTE: The instructions for cylinder head removal and refitting given in frames 2 and 3 are servicing procedures with the engine in the car.

Instructions for cylinder head refitting during a complete engine rebuild are different, and details are given on page 40.

Disconnect the throttle linkage.

Disconnect the petrol feed pipe, water pipes and crankcase breather pipe from the camshaft cover.

Remove the distributor vacuum advance pipe.

Remove the six bolts and washers securing the inlet manifold to the cylinder head.—Slant 4, 10 bolts and washers on 16 valve engines.

The carburetters and inlet manifold may now be removed as an assembly.

Remove the camshaft cover together with the distributor cap and h.t. leads.

Remove the exhaust manifold.

Using a nut from one of the camshaft middle bearing caps, secure the mounting bracket to the camshaft chain sprocket as shown in the illustration. The nut must be TIGHT.

Failure to observe these precautions will result in the chain sprocket dropping slightly, thus allowing the timing chain tensioner to expand to the non-retractable condition.

If this occurs, it will be necessary to remove the front timing cover and chain tensioner and reset the timing as described on pages 43 and 44.

Turn engine until No. 1 piston is at T.D.C. firing.

Turn engine BACK half a revolution; this will expose one of the bolts securing the camshaft chain wheel.

Knock back tab washer and remove bolt.

Turn engine to T.D.C. No. 1 firing and remove other chain sprocket retaining

16 VALVE SLANT 4
ENGINE

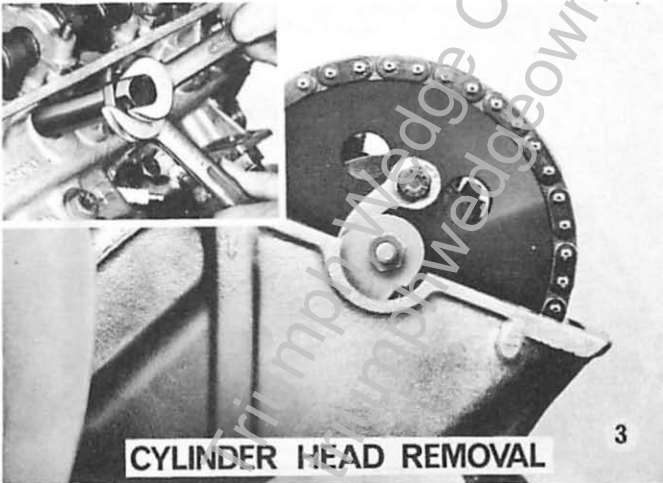
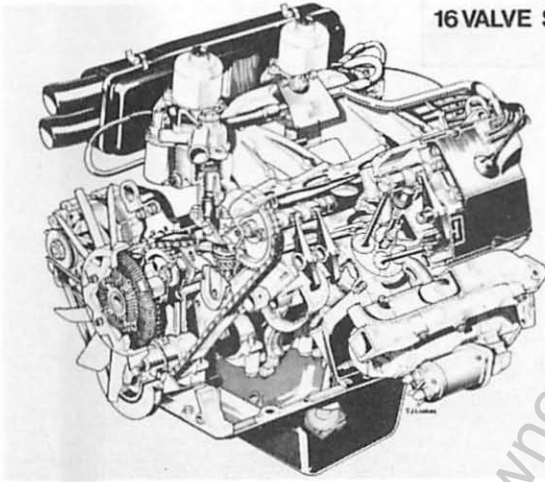

CYLINDER HEAD REMOVAL

Provided Courtesy <http://www.computerwedge.computerwedgeowners.org>

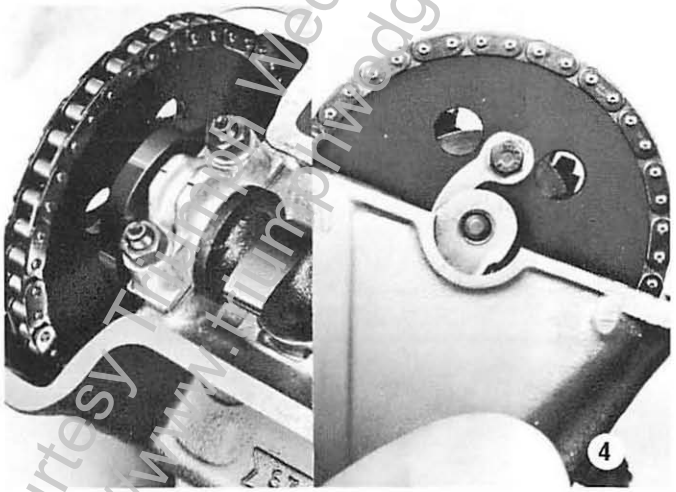

Provided Courtesy of the <http://www.WedgeOwners.org> Wedge Owners Association

bolt and tab washer.

NOTE: Great care is necessary when removing or refitting chain sprocket bolts and tab washer. Should the bolts or tab washers fall into the engine it may be necessary to strip the engine down to retrieve them.

Pull the chain sprocket free from the camshaft.

If the engine is in the car, remove all the cylinder head studs using tool No. S.350.

Remove the cylinder head bolts at either end of the head and replace by two shortened studs to facilitate dismantling.

If the long cylinder head studs are used the head will foul the wing valence.

Remove all other bolts, including the special bolts, washers and nuts securing the head to the front timing cover.

Remove the cylinder head and gasket.

For refitting cylinder head and timing sequence refer to pages 40-41.

16 VALVE ENGINE

CYLINDER HEAD REMOVAL—ENGINE IN CAR

If the cylinder head is to be removed with the engine in the car, then it will be necessary to make up two short studs $3\frac{3}{16}$ in (80.9 mm) in length. The length of thread on the stud MUST be $1\frac{3}{32}$ in (27.7 mm).

Cut a screwdriver slot in the end of the stud to facilitate removal and refitting.

The short studs should be fitted into two of the cylinder head bolt holes.

FRAME 4

CYLINDER HEAD—SERVICE REFITTING

Ensure engine is at T.D.C. No. 1 firing.

Replace cylinder head gasket.

Ensure camshaft timing mark aligns with mark on front camshaft bearing cap.

Using two shortened cylinder head studs as guides lower cylinder head into position and secure with ten studs nuts and bolts.

NOTE: Ensure distributor cap spring clip is not trapped between cylinder head and block.

Tighten head bolts and nuts, following sequence given on page 8.

Fit two special bolts nuts and washers securing cylinder head to front timing cover.

Offer up timing chain wheel spigot to camshaft. **DO NOT REMOVE NUT SECURING CHAIN WHEEL TO BRACKET.**

Secure chain wheel to camshaft with bolt and tab washer. **DO NOT** tighten fully.

Turn crankshaft until it is possible to fit remaining chain wheel to camshaft securing bolt and tab washer.

Fully tighten both bolts to 7 to 10 lbf ft (0.9 to 1.3 kgf m) and bend over tabs.

Finally remove nut securing chain wheel to bracket.

Ensure there is clearance between hole in bracket and threaded spigot on chain wheel.

Attach gaskets to inlet manifold.

Fit new 'O' ring to inlet manifold flange; smear with rubber grease.

Offer up inlet manifold with carburettors to cylinder head.

Engine lifting bracket and heater bracket are fitted to rear flange on inlet

manifold.

Secure with six bolts and washers.

NOTE: Long bolts used on flange with engine lifting bracket.

Remove thermostat top cover and thermostat.

Gently press a NEW water seal into position through the thermostat housing to line up with the water pump housing as described on page 51.

Refit thermostat, new gasket and top cover.

Refer to page 19 for cam cover refitting.

Refit air cleaner. Refit throttle linkage, petrol pipe, distributor vacuum pipe and cables. Refit heater pipes.

FRAME 5

CYLINDER HEAD

The cylinder head nuts and bolts should be tightened progressively in the sequence shown.

Tighten all cylinder head nuts and bolts to 45 to 55 lbf ft (6.2 to 7.6 kgf m).

FRAME 6

CAMSHAFT

The camshaft has five bearings, which run in the alloy head.

No. 1 bearing cap has indents on the top face for timing purposes.

The other bearing caps are numbered and their corresponding number cast in the cylinder head.

The bearing caps locate onto long and short dowels to prevent incorrect fitting.

Progressively slacken bearing cap nuts, otherwise damage to the camshaft may result.

When refitting, tighten camshaft bearing cap nuts to 10 to 14 lbf ft (1.4 to 1.9 kgf m).

NOTE: Great care should be taken when handling cylinder head with the camshaft in position, due to the valves projecting below the face of the head.

CYLINDER HEAD TIGHTENING SEQUENCE

45-55lb ft (6.2-7.6 kgf m)

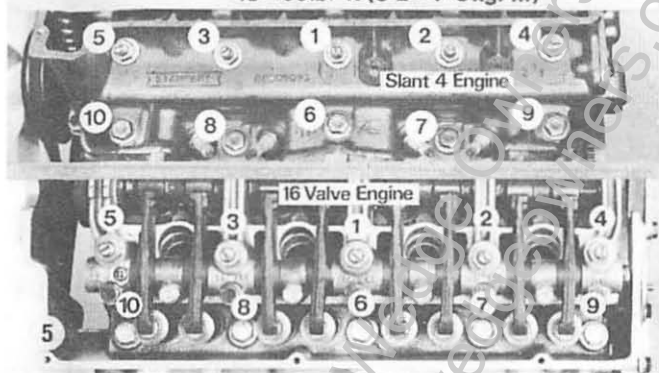

CAMSHAFT ASSEMBLY

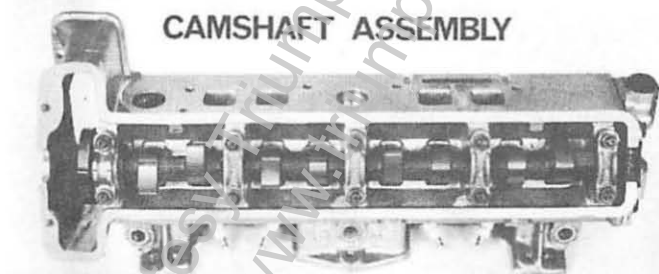

CAMSHAFT BEARING CAP NUTS
10-14 lb.ft. (1.4-1.9 kgf.m.)

6

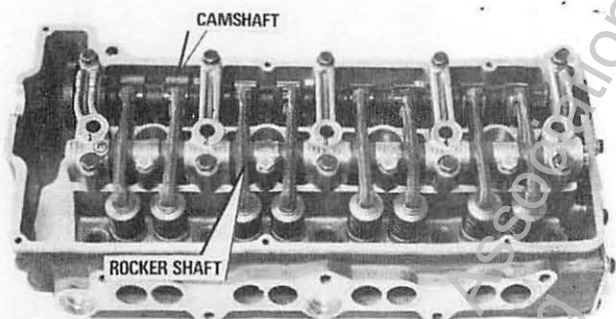

**CAMSHAFT AND ROCKER SHAFT
BEARING CAPS**

7

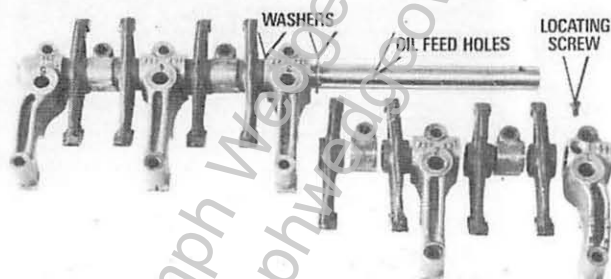

ROCKER SHAFT ASSEMBLY

8

VALVE ASSEMBLY

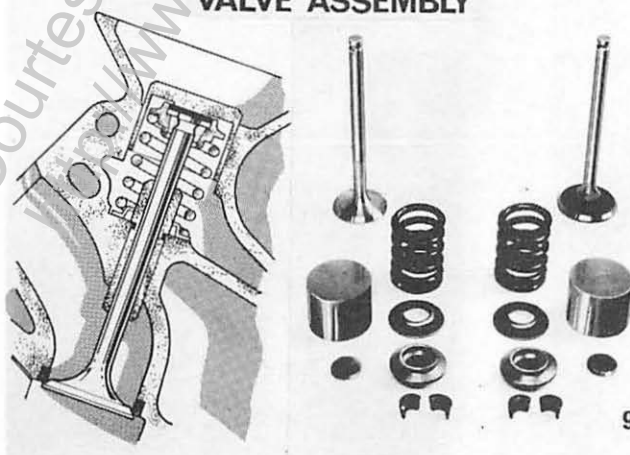

9

FRAME 7

CAMSHAFT AND ROCKER SHAFT BEARING CAPS- 16 VALVE ENGINE

The camshaft as fitted to the 16-valve engine has a dual role. The lobes of the camshaft operate directly onto the tappets of the inlet valves and the same lobes are used to operate the exhaust valves via rockers.

The camshaft and rocker shaft share five common bearing caps which are numbered.

No. 1 bearing cap has an indent on the top face for timing purposes.

The bearing caps are located onto the cylinder head by hollow dowels.

The camshaft and rocker shaft are secured by 14 bolts.

When the shafts are removed or refitted to the cylinder head the bolts must be slackened or tightened progressively to avoid possible damage to the two shafts. Bearing cap torque setting is 12 to 16 lbf ft (1.6 to 2.2 kgf.m).

NOTE: Great care should be taken when handling the cylinder head with the camshaft in position, due to the valves projecting below the face of the head.

FRAME 8

ROCKER SHAFT ASSEMBLY- 16 VALVE ENGINE

The rocker shaft assembly is supported on five bearing caps and also by four intermediate bearings separating the rockers.

Assembly of the rocker shaft is shown in the illustration. Note the position of the keeper screw on No. 1 bearing cap and also the washers fitted on either side of No. 3 bearing cap.

NOTE: When fitting rockers to shaft ensure that pairs of rockers are angled towards each other.

The rocker shaft and rockers are fed with lubricating oil via the end bearing caps.

FRAME 9

TAPPETS

Number each tappet and location when removing them from the cylinder head.

Always place the adjusting pallets with their appropriate tappet.

Failure to carry out these instructions will cause incorrect tappet clearances.

An exploded view of the valve assembly items is shown in the illustration.

NOTE: The valve springs must be fitted with the close coil to the bottom.

FRAME 10

VALVE ASSEMBLY-16 VALVE ENGINE

As shown above, the inlet valves have tappets and the exhaust valves are operated by the rocker acting directly on to the adjusting pallet.

Number each valve, tappet and adjustment pallet for location when removing them from the cylinder head.

Always keep the adjustment pallets with their appropriate tappet.

Failure to carry out these instructions will cause incorrect tappet clearances.

NOTE: Valve springs must be fitted with the close coil to the bottom.

FRAME 11

VALVE REMOVAL-SLANT 4 AND 16 VALVE ENGINES

Remove each valve and spring, using tool No. 18G 106 (RG 6513) and adaptor S 352.

Remove the cotters, top cup, spring, bottom cup and valve.

NOTE: The inlet and exhaust valve springs are identical and should be fitted with the close coil to the bottom.

Refitting is the reverse of the removal procedure.

Ensure the spring and cotters are fully seated.

FRAME 12

VALVES

Before starting to grind valves it is most important that all valves are numbered so that they are kept to their respective valve seats.

1. Clean all valves and seats.
2. Inspect valves for bent stems, eccentricity of head, and pock-marks.
3. Inspect valve seats for pocketing, pock-marks, cracks, and distortion.
4. If there are deep pock-marks in the valve seats, deglaze and re-cut seat to 45° before grinding in valves.

Illustration 'A' shows a correctly seating valve.

Illustration 'B' shows a 15° cutter used to reduce the width of the valve seat.

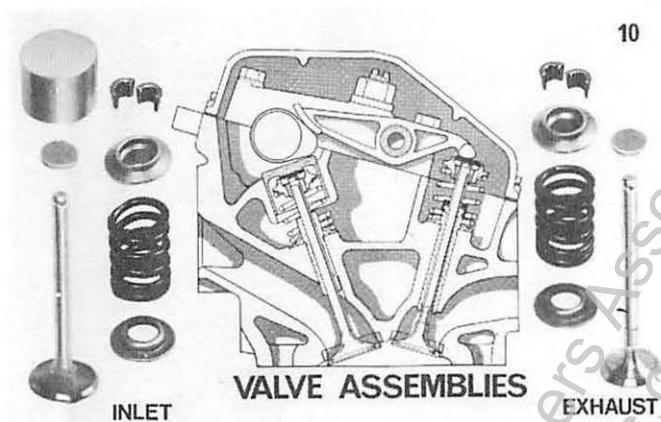

CORRECTLY SEATED VALVE

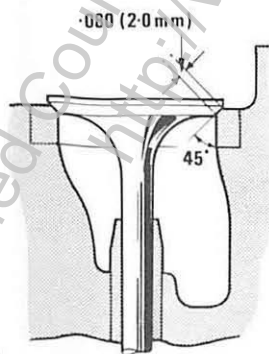

SEAT WIDTH REDUCING CUTTER

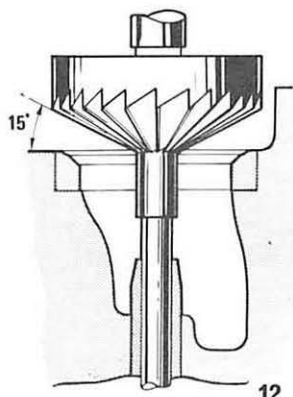

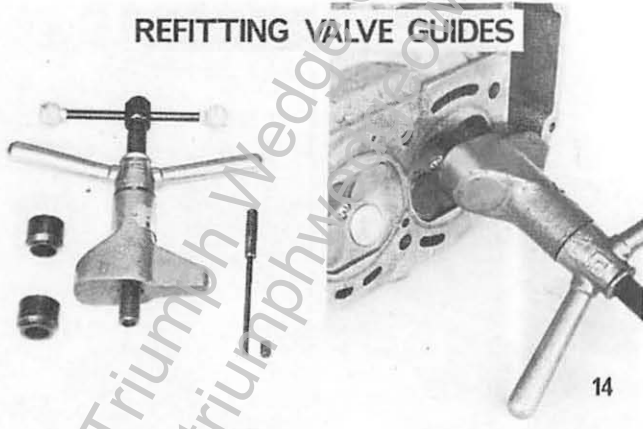
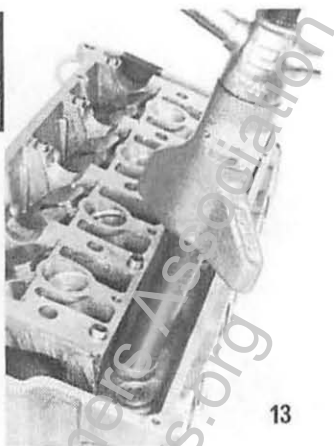
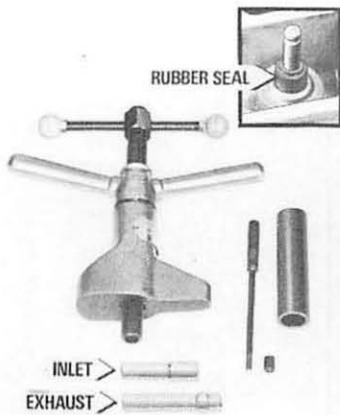

VALVE GUIDES—REMOVAL

SLANT 4 ENGINES

The inlet and exhaust valve guides are identical. A step is machined into the guide similar to that shown on the inlet valve guide in the illustration.

Use special tool No. 60A and S60 A2 and withdraw the valve guide from the head.

16 VALVE ENGINES

The inlet and exhaust valve guides differ in length. The exhaust valve guide is the longest, with an extra groove at one end for a rubber oil seal which also fits around the valve stem.

NOTE: DO NOT heat the cylinder head to aid extraction of valve guides. To remove the inlet and exhaust valve guide use special tools S60A-9/4 and /5 in conjunction with a spacer tube S60A-9/1.

As there is a step machined in the valve guides the guide must be withdrawn upwards towards the camshaft side of the cylinder head.

FRAME 14

VALVE GUIDES—REFITTING

DO NOT replace the original valve guides. Replacement valve guides must be 0.002 in (0.05 mm) oversize.

SLANT 4 ENGINES

Using special tool No. 60A and S60A2 in conjunction with adaptor 60A8 pull the valve guide into position after applying graphite to the guide and head.

Pull the guide into position to the machined step.

Ream the valve guides using a $\frac{7}{16}$ in (7.9 mm) reamer.

NOTE: It is essential after fitting new valve guides to re-cut the valve seats.

16 VALVE ENGINES

To replace the valve guides use special tool No. S60A-9/4 and /5 in conjunction with: Exhaust Guide Adaptor S60A-9/3

Inlet Guide Adaptor S60A-9/2

NOTE: Two adaptors are used due to differences in valve head diameters.

Before replacing the valve guides it is essential to apply graphite grease to the guides and cylinder head.

Pull the guide into position to the machined step.

Ream the valve guides using two reamers of British Standard length $6\frac{7}{16}$ in (16.4 cm). The first cut reamer should be $\frac{11}{16}$ in (6.74 mm) diameter. The final cut reamer should be $\frac{9}{32}$ in (7.14 mm) diameter.

NOTE: It is essential, after fitting new valve guides, to re-cut the valve seats.

VALVE CLEARANCE ADJUSTMENT

SLANT 4 ENGINE

Clean all oil from tappets and adjustment pallets.

Refit complete set of pallets and tappets in their original positions.

Place camshaft in position and fit numbered camshaft bearing caps.

Turn cylinder head onto exhaust flange to avoid damage to valves.

Tighten camshaft bearing cap nuts progressively to 12 to 16 lbf ft (1.6 to 2.2 kgf m).

Using a spanner on the cast hexagon at the rear of camshaft to rotate the cams, and using feeler gauges, check the clearance between the cam base and tappet as shown.

Clearances: INLET 0.008 in (0.2 mm) } Cold.
EXHAUST 0.018 in (0.45 mm) }

The pallets are available in sizes from 0.070 in to 0.114 in (1.7 to 2.9 mm) thickness in increments of 0.001 in (0.02 mm).

EXAMPLE

If the reading obtained on an exhaust valve is 0.012 in (0.3 mm), a pallet of **decreased** thickness (i.e. 0.006 in (0.15 mm) less) must be fitted to give the correct clearance of 0.018 in (0.45 mm).

NOTE:

If it is necessary to adjust the tappets on the Slant 4 or 16 valve engines with the head assembled to the block the following sequence **MUST BE USED**.

Set the engine to T.D.C. No. 1 cylinder firing. Disconnect the timing chain wheel from the camshaft as described in Frame 3. Turn crankshaft **ANTI-CLOCKWISE** through 90°. It is then permissible to rotate the camshaft as necessary to adjust the tappets.

When the tappets have been correctly set line up the camshaft timing marks.

Turn the crankshaft **CLOCKWISE** through 90° to the T.D.C. position and refit the timing chain.

FRAME 16

16 VALVE ENGINE

Refit the complete set of pallets and tappets in their original positions. Place the camshaft and rocker shaft into position together with the camshaft bearing caps. Turn the cylinder head onto the exhaust flange to avoid damage to the valves. Tighten the camshaft and rocker shaft bearing cap nuts progressively to 12 to 16 lbf ft (1.6 to 2.2 kgf m).

Using a spanner on the cast hexagon at the rear of camshaft to rotate the cam, and using feeler gauges, check the clearance between the cam base and tappet as shown.

Clearances: INLET AND EXHAUST 0.018 in (0.45 mm) cold.

Note the readings obtained on all tappets and if not within the tolerance given remove the camshaft and rocker shaft as described in Frame 15 and alter the pallets to suit.

**CHECKING VALVE CLEARANCES
SLANT 4 ENGINE**

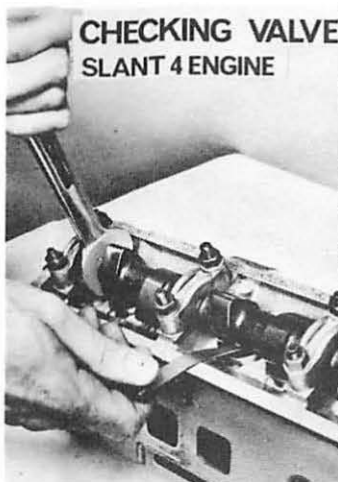

**TAPPET IN POSITION
AND PALLET BEING
REFITTED**

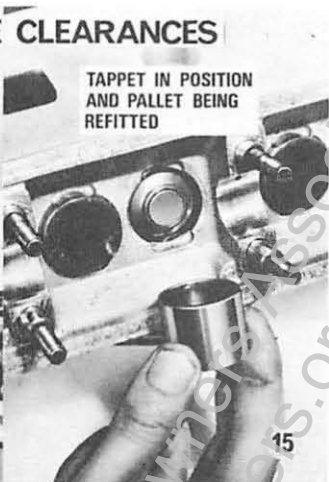

15

**CHECKING VALVE CLEARANCES
16 VALVE ENGINE**

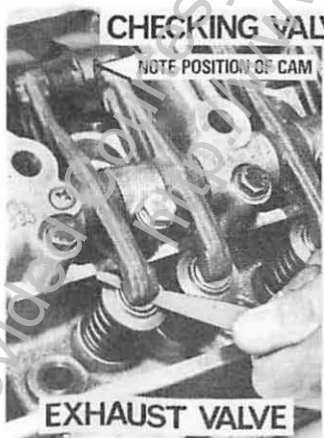

NOTE POSITION OF CAM

EXHAUST VALVE

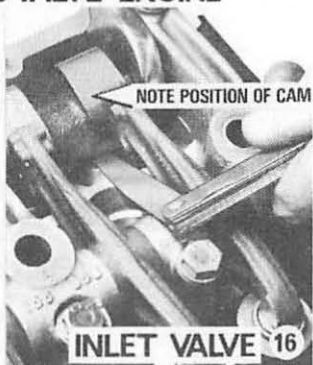

NOTE POSITION OF CAM

INLET VALVE 16

REFITTING CAMSHAFT COVER

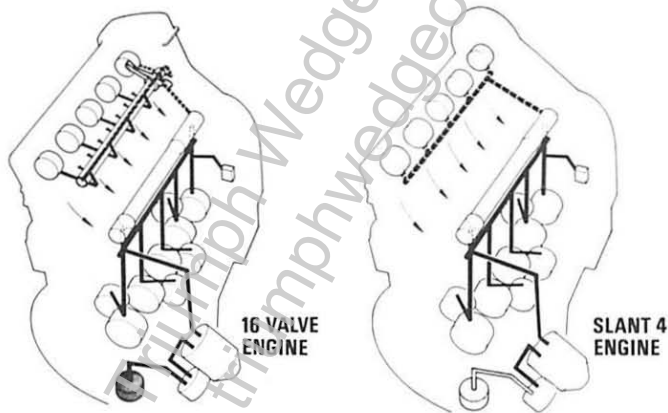
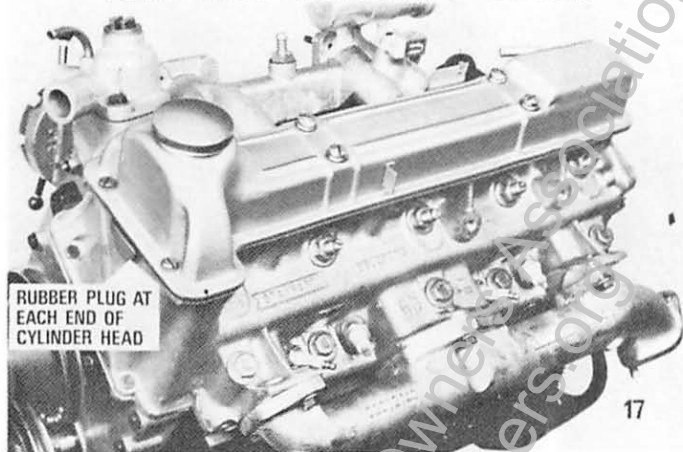

LUBRICATION DIAGRAM

18

CAMSHAFT COVERS

Refer to pages 8-11 for appropriate camshaft refitting instructions.

Fit bolts securing chain sprocket to camshaft.

NOTE: DO NOT rotate engine with cylinder head in position and camshaft chain sprocket disconnected.

Rotate engine until the remaining sprocket to camshaft securing bolt can be fitted. Tighten to 7 to 10 lbf ft (1.0 to 1.4 kgf m) and knock over tab washer.

Replace the two rubber plugs on cylinder head.

Fit gasket and replace the camshaft cover and secure with four special screws, six screws on 16 valve engines.

Fit two screws and washers securing front of camshaft cover to the cylinder head.

Connect the crankcase emission pipe from the carburettors to the camshaft cover.

Clip the distributor h.t. leads to the camshaft cover, using plastic clips.

PART 2

LUBRICATION

The engine is fitted with a wet sump system.

The oil pump is driven by the idler shaft via the distributor gear.

Oil is drawn from the sump through a wire filter to the pump and pressure relief valve.

Oil then passes through an external full-flow element type filter and then to the main oil gallery via the transfer port.

From the main gallery oil is distributed to all bearings and moving parts.

Oil is fed to the camshaft from an intermittent feed on the idler shaft front bearing.

Drain holes in the head and idler shaft tunnel allow oil to return to the sump.

On 16 valve engines the oil is fed from the idler shaft to the rocker shaft via the front angled cylinder head stud.

Oil is distributed via the hollow rocker shaft to all camshaft bearing caps and rockers.

FRAME 19

OIL PUMP

An external oil pump secured to the crankcase by four bolts and washers tightened to 15 to 20 lbf ft (2.0 to 2.8 kgf m). The oil pump is driven by the idler shaft via the distributor.

An 'O' ring provides a seal between the pump and block.

The oil pressure with the engine at correct running temperature should be 45 to 55 lb/in² (3.2 to 3.9 kg/cm²).

An oil pressure relief valve is fitted integral with the oil pump base plate and consists of:

- A. Relief valve
- B. Spring
- C. Spring location plug and 'O' ring
- D. Split pin securing relief valve to assembly

FRAME 20

The oil pump consists of an inner and outer rotor. The following points should be checked during overhaul.

- (a) Inner and outer rotors when assembled in the pump body must not exceed 0.004 in (0.10 mm) end-float.
- (b) The end-plate must be perfectly flat and free of scores.
- (c) The clearance between outer rotor and pump body must not exceed 0.008 in (0.20 mm).

NOTE: The chamfer on outer rotor is innermost.

FRAME 21

Clearance between the inner and outer rotors is very important and must not exceed 0.010 in (0.25 mm).

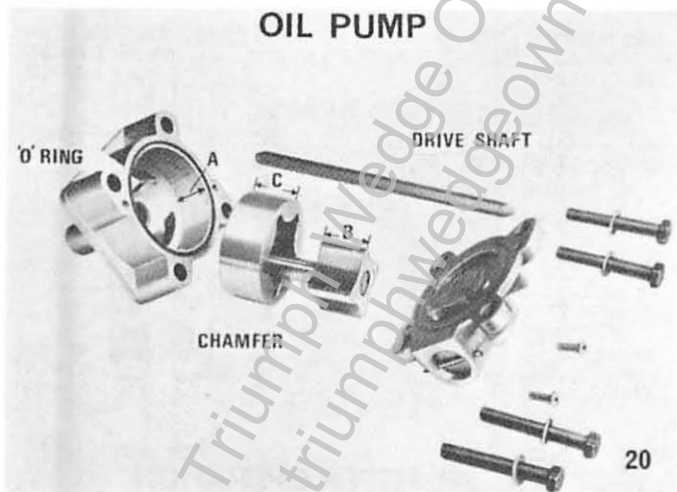
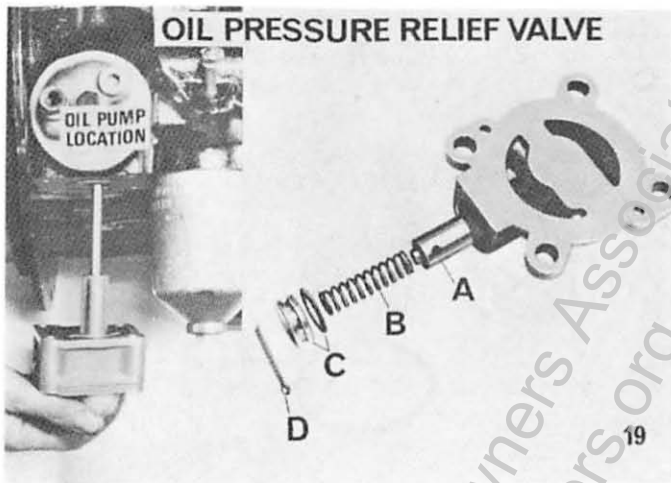

OIL FILTER ASSEMBLY



22

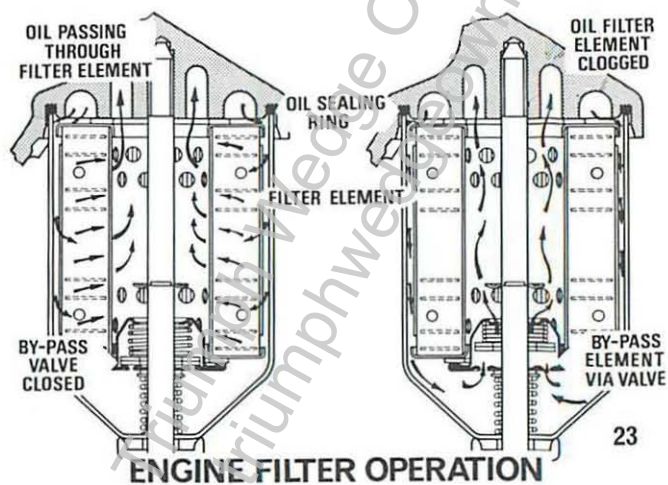

23

ENGINE FILTER OPERATION

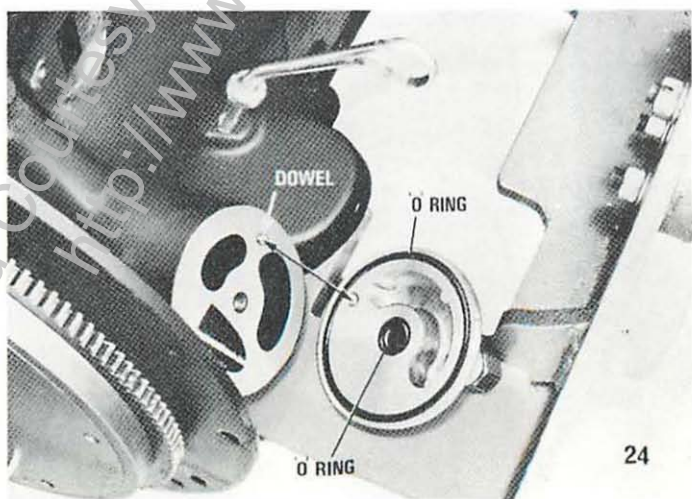

24

FRAME 22

OIL FILTER

The oil filter is of the full-flow type fitted with a paper element, which must be changed at regular intervals according to operational conditions—see vehicle handbook.

The filter body is secured to the side of the cylinder block by a central bolt. Oil sealing between filter body and crankcase is by a rubber ring.

FRAME 23

The left-hand diagram shows how the oil passes through the filter element to the main oil gallery.

The right-hand diagram shows what happens to the oil if the filter element becomes blocked.

The oil by-passes the element via a spring-loaded valve.

This safety valve is essential to prevent starvation of oil to the bearings.

FRAME 24

OIL TRANSFER HOUSING

The housing is secured to the block by a single bolt and washer and is sealed by two 'O' rings.

Tighten bolt to 26 to 32 lbf ft (3.6 to 4.4 kgf m).

PART 3

CRANKCASE VENTILATION- SLANT 4 AND 16 VALVE ENGINES

The camshaft cover has a gauze filter fitted integral with the cover.

A rubber pipe from the gauze filter is connected to the constant depression side of the carburetters.

Every 12,000 miles (20000 km.) clean the camshaft cover gauze filter and pipe with methylated spirits (denatured alcohol). Ensure the breather pipes are clean and serviceable. If excessive contamination is apparent in the system it will be necessary to dismantle the carburetters and clean the air valve and body.

PART 4

CRANKSHAFT AND ASSEMBLIES

The four-throw crankshaft is counterbalanced and has five main bearings.

Drillings through the crankpins to communicate with the main journals form an integral part of the lubrication system.

When overhauling the engine, check taper and ovality of crankpins and main journals which must not exceed 0.002 in (0.05 mm).

If the crankshaft requires regrinding, check with manufacturer for safe working limits.

Crankshaft end-float is controlled by thrust washers on either side of the crankcase half of the centre main bearing.

When fitted, the centre main bearing cap overlaps the thrust washers and prevents them rotating.

The bearing surface and sludge grooves on the thrust washers should be fitted to face the crankshaft.

CRANKCASE VENTILATION

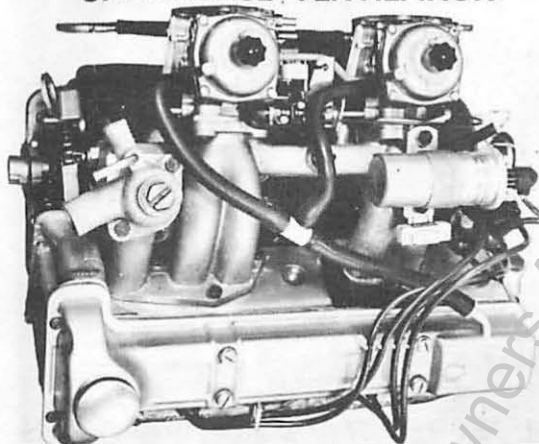

25

CRANKSHAFT ASSEMBLY



26

MAIN BEARING

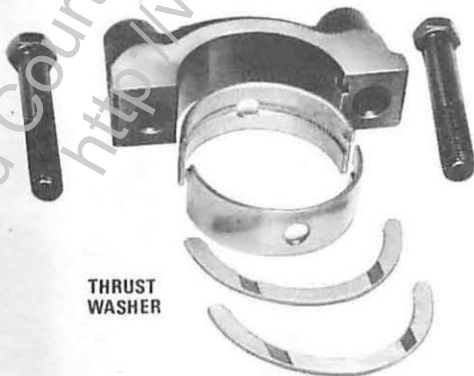

THRUST
WASHER

27

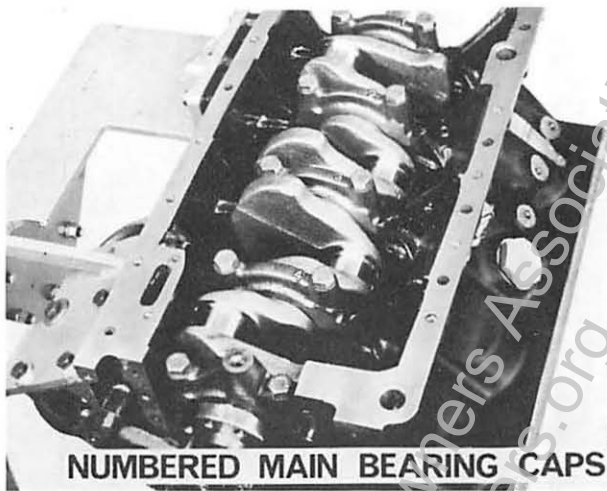

NUMBERED MAIN BEARING CAPS

28

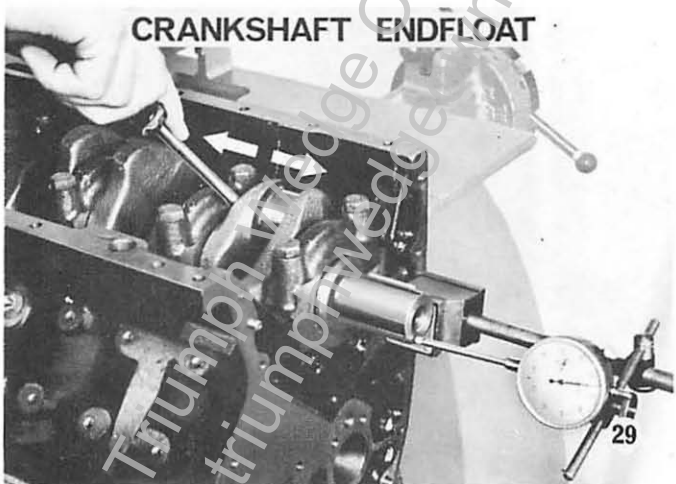

CRANKSHAFT ENDFLOAT

29

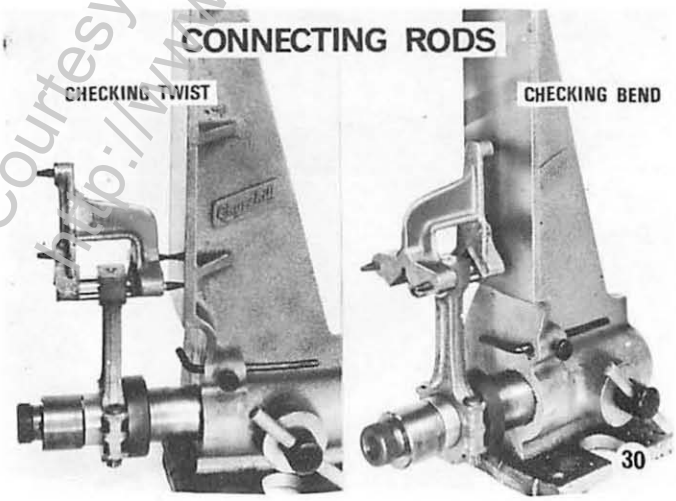

CONNECTING RODS

CHECKING TWIST

CHECKING BEND

30

CRANKCASE ASSEMBLY

The crankshaft is supported in five main bearings of the steel-backed shell type. The bearing material is phosphor-bronze overlaid with lead-indium.

Before assembly, thoroughly clean all parts and inspect for defects. Re-assemble the crankshaft following the procedure given below.

NOTE: All main bearing shells are same width.

1. Fit main bearing shells to the crankcase and smear with oil.
2. Fit crankshaft and slide crankshaft thrust washers into position on either side of the centre main journal.

NOTE: Bearing material towards crankshaft.

3. Fit bearing shells into main bearing caps and smear with oil.
4. Fit all main bearing caps, with the numbers cast on top of caps in their correct order and facing away from the oil filter, No. 1 at the front of crankcase.

The main bearing cap numbers are also cast into the webs on the crankcase.

NOTE: Number 5 main bearing cap is not numbered but has a boss cast on the top.

5. Tighten the ten crankshaft main bearing cap bolts progressively to 50 to 65 lbf ft (6.9 to 8.9 kgf m).

Check crankshaft for free rotation.

FRAME 29

To check the crankshaft end-float the following procedure should be followed.

1. Make sure all main bearing caps are tightened to the correct torque, 50 to 65 lbf ft (6.9 to 8.9 kgf m).
2. Force the crankshaft away from the main bearing thrust washer and with a dial indicator as shown check that the end-float is within limits of 0.003 to 0.011 in (0.07 to 0.28 mm).

FRAME 30

CONNECTING RODS AND PISTONS

To check the connecting rods for distortion a jig as shown should be used in conjunction with tool No. 336/3, arbor adaptor.

The right-hand illustration shows the fixture set for checking BEND.

The left-hand illustration shows the fixture set for checking TWIST.

The amount of error is indicated by malalignment of the 'V' block pegs in relation to the machined face.

The amount of BEND must not exceed 0.0015 in (0.038 mm) for length of gudgeon pin.

The amount of TWIST must not exceed 0.0015 in (0.038 mm) per inch length of gudgeon pin, e.g. 0.0045 in (0.15 mm) for 3 in (7.62 cm) length.

To simplify the process of assembly the pistons and cylinder bores are graded for size. The difference between each grade is 0.0005 in (0.012 mm).

CYLINDER BLOCK

The piston grading letters are stamped onto the cylinder block in the position shown in the illustration.

PISTONS

The piston grade is stamped onto the crown of the piston and the front denoted by a triangle.

When the cylinders have been re-bored the grade letters no longer have any meaning.

Steel bands, integral with the side wall of the piston, are used to stabilize the shape of the piston throughout the working temperature range.

PISTON RINGS

No. 1 Compression

No. 2 Scraper—Stepped ring top face marked 'TOP'

No. 3 Scraper—Spring oil control.

ASSEMBLING PISTONS AND CONNECTING RODS

Select the correct grade of piston.

Assemble piston and connecting rod so that the front of the piston is towards the front of the engine and the markings stamped on the side of the connecting rod face AWAY from the idler shaft.

NOTE: When fitting a new (unstamped) connecting rod to a piston ensure that the big-end bearing retaining tag slots are farthest away from the idler shaft.

Fit one circlip to the recess in the piston.

Apply oil to the little-end bush. With the connecting rod held in position, press in gudgeon pin and secure with remaining circlip.

16 VALVE ENGINES

Early production engines were fitted with 'dished' top pistons, but on later engines flat top pistons are fitted. Both types of pistons have cut-outs for the inlet valves but they are not interchangeable, i.e. engines must be fitted with a complete set of the same type of piston.

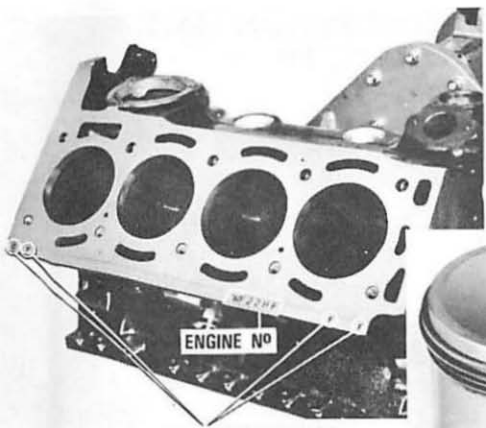

CYLINDER BORE GRADE LETTERS



31



CON ROD NUMBERS

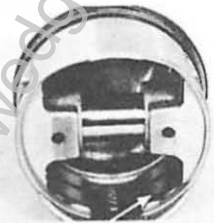

PISTON STABILISING BANDS



BIG END BEARING TAGS

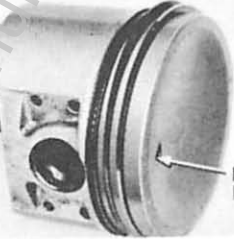

32

FRONT OF PISTON

Provided Courtesy of Triumph Wedge Owners Association
<http://www.triumphwedgeowners.org>

**FITTING PISTON AND
CONNECTING ROD**

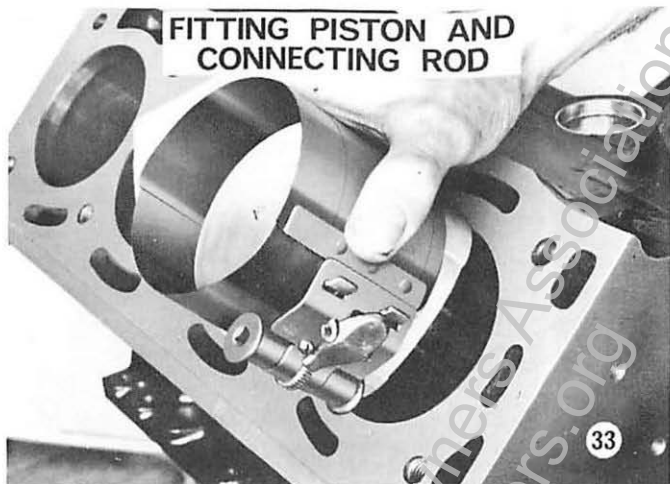

33

**CHECK OIL SEAL IS
FLUSH WITH HOUSING**

FITTING REAR OIL SEAL



34

OIL PICK-UP ASSEMBLY



35

FITTING THE PISTONS

The piston and connecting rod assembly is installed from the top of the cylinder block using the following procedure.

1. Space the piston ring gaps evenly round the piston ensuring there are no gaps on the thrust side, i.e. side of piston farthest away from the jackshaft.
2. Lubricate the pistons and rings thoroughly.
3. Fit piston ring clamp to piston.
4. Feed piston and connecting rod assembly into bore of cylinder block.
NOTE: Care being taken that piston mark is facing front of engine.
5. Fit bearing shells to connecting rod big-end and lubricate bearings.
NOTE: Connecting rod big-end caps stamped 1 to 4 consecutively from the front of crankshaft.
6. Ensure bearing caps are fitted with corresponding numbers together.
7. Fit big-end bearing caps and tighten nuts to 40 to 45 lbf ft (5.5 to 6.2 kgf m).

FRAME 34

REAR OIL SEAL

With the lip facing inwards, place the rear oil seal in the aluminium housing and press in until face of the seal and seal housing are flush. Check with a straight-edge.

Place housing gasket into position on block.

Lubricate the rear of the crankshaft with oil and gently ease rear oil seal and housing over the lead on the rear of crankshaft.

NOTE: Line up the two dowel holes in the rear oil seal housing with dowel pins in block.

Fit six bolts and spring washers, the two longer bolts being fitted to the bottom holes of the housing, and tighten to 6 to 9 lbf ft (0.8 to 1.2 kgf m).

FRAME 35

OIL PICK-UP AND SUMP

The oil pick-up and gauze screen is held in position by two bolts and spring washers.

A gasket is fitted between the oil pick up and the cylinder block.

NOTE: If desired, the sump may be fitted at this stage but all the sump bolts must be left slack to facilitate fitting the front timing cover at a later stage.

Replace sump gasket.

Replace sump and fit 14 bolts and washers.

Two extra-long bolts and nuts with special washers are fitted in two clearance holes drilled in the crankcase. The remaining two nuts, bolts and washers secure the sump to the front timing cover.

When engine is fully assembled tighten all bolts to 15 to 20 lbf ft (2.1 to 2.8 kgf m).

REAR ENGINE PLATE

The rear engine plate is located onto the rear of the cylinder block by two dowels.

Offer up the plate to the dowels and secure with six bolts—no washers. Tighten to 15 to 20 lbf ft (2.1 to 2.8 kgf m).

FRAME 37

FITTING THE FLYWHEEL

Fit the gearbox mainshaft spigot bush to the rear of the crankshaft. Remove any high spots around the bolt holes and the end of the crankshaft with a smooth file or flat oil-stove, and clean thoroughly.

EARLY DOLOMITE ENGINES

Up to engine number WF 23468 the flywheel was located by a Mills pin and secured with a retainer plate and six bolts.

NOTE: As the flywheels are no longer Mills pin located the flywheel and crankshaft should be marked to facilitate refitting. Failure to do this may result in the flywheel being out of its original position and consequently the timing mark on the flywheel will be useless.

CURRENT ENGINES

From the above Dolomite engine number and all Sprint engines the flywheels are NOT located by a Mills pin but are now secured by eight bolts and a retainer plate. The retainer plate prevents the spigot bush becoming displaced when the gearbox is removed.

NOTE: The special bolts securing the flywheel to the crankshaft have a nylon insert and **MUST BE RENEWED** before each fitting. Failure to observe these instructions may result in oil creeping along the bolts and contaminating the clutch assembly.

Tighten the bolts to 40 to 45 lb ft (5.5 to 6.2 kgf m).

UNDER NO CIRCUMSTANCES MUST an eight hole flywheel be fitted to a six bolt crankshaft OR a six hole flywheel be fitted to an eight bolt crankshaft.

Check flywheel run-out, which must not exceed 0.004 in (0.1 mm) at a 4 in (10.1 cm) radius.

Using marks stamped on the flywheel and cylinder block, turn engine until No. 1 piston is at T.D.C.

The cast-iron flywheel has a hardened steel starter ring which can be replaced if the teeth become worn. The clutch assembly may be left off until a later stage to facilitate timing the engine.

REAR ENGINE PLATE

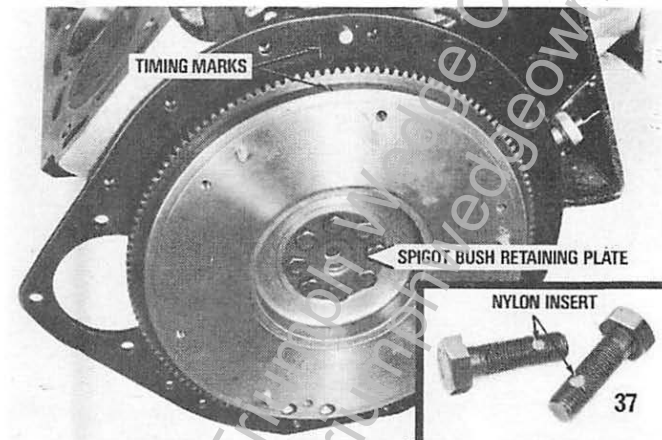
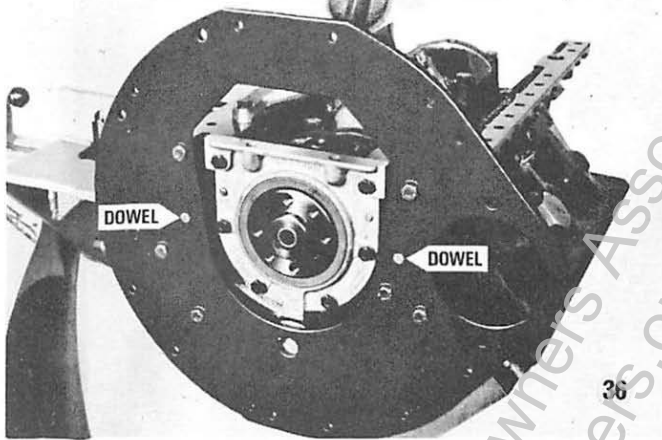

REFITTING IDLER SHAFT GEAR

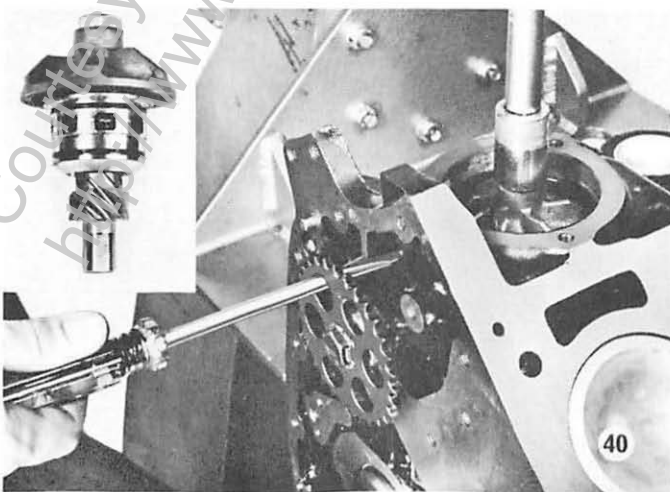

FRAME 38

IDLER SHAFT

The idler shaft is supported at either end in the cylinder block and is driven by the timing chain.

The idler shaft has two skew gears machined into it, the front one driving the water pump and the rear one the distributor. The idler shaft also drives the petrol pump by means of an eccentric lobe on the shaft.

Hold the idler shaft firmly in a vice.

Place the idler shaft chain wheel, with the scribe line facing forwards, onto the idler shaft and align either of the dowel holes in the chain wheel with the dowel.

Fit the special tag washer to fit in the unused dowel hole.

Fit bolt and tighten to 30 to 38 lbf ft (4.1 to 5.3 kgf m).

Knock tab washer segment onto bolt head.

Lubricate the idler shaft bearing and gear surfaces and slide into position in cylinder block.

NOTE: Check idler shaft gear for run-out.

FRAME 39

Locate the idler shaft retaining plate into position in the annular groove on the shaft.

Fit the two $\frac{3}{16}$ in (4.7 mm) Allen screws securing the plate to cylinder block and tighten to 16 to 22 lbf ft (2.2 to 3.0 kgf m).

FRAME 40

REFITTING WATER PUMP

The water pump housing is situated above the idler shaft integral with the cylinder block.

The impeller-type pump is driven by a skew gear on the idler shaft.

NOTE: When removing the water pump apply a socket spanner to the bolt head, which has a LEFT-HAND thread, and gently rock in a clockwise direction with the idler shaft held stationary. If assembly does not unscrew and disengage itself from the block due to tightness, the bolt securing the impeller will unscrew. The pump assembly can then be removed using an impact hammer and adaptor 54235A/6 4235A (3072) (see pages 70-71).

Before refitting the water pump, ensure that the pump spigot bearing in the cylinder block is in good condition. Place water pump assembly in position in cylinder block and slowly rotate the idler shaft to mesh gears. Fit socket to impeller retaining bolt and turn in an anti-clockwise direction to fully seat assembly, at the same time holding the idler shaft stationary.

NOTE: Do not tap nut with hammer to seat pump as this may fracture the graphite seal.

The Stag V8 and Dolomite/Sprint water pump impellers are not interchangeable.

FRAME 41

FITTING WATER PUMP HOUSING

Assemble the water pump housing to the cylinder block without gaskets. Fit the three securing bolts finger-tight.

Using feeler gauges between the housing and cylinder block adjust the gap, by means of the bolts, to give an equal reading on the three segments.

Select gaskets to give 0.010 to 0.020 in (0.25 to 0.5 mm) clearance between the impeller retaining bolt and lug on housing.

Example:

Gap between housing and block 0.010 in (0.25 mm).

Gaskets selected—total thickness 0.025 in (0.63 mm).

Clearance obtained 0.015 in (0.38 mm).

Fit the heater pipe to the water pump housing, then secure the housing to the block with three bolts and plain washers tightened to 15 to 20 lbf ft (2.1 to 2.8 kgf m).

FRAME 42

CHAIN SPROCKET ALIGNMENT

It is essential that the idler sprocket and crankshaft drive sprocket are checked for alignment using a straight-edge as shown on the above Slant 4 engine.

If the sprockets do not line up, place the appropriate amount of shims behind the sprocket on the crankshaft, fit Woodruff key and replace sprocket.

There are two sizes of shims, 0.004 in (0.10 mm) and 0.006 in (0.15 mm).

16 VALVE ENGINES

Although the 16 valve engines are fitted with twin sprockets for a Duplex chain the same alignment check may be used.

FRAME 43

CHAIN TENSIONERS

The timing chain tensioner is of the hydraulic type and consists of an oil-resistant rubber slipper mounted on a plunger which bears on the outside of the chain. The spring, cased by the restraint cylinder and the plunger, in combination with oil pressure holds the slipper head against the chain, keeping it in correct tension.

Return movement of the slipper head is prevented by the limit peg at the bottom end of the plunger bore engaging the nearest tooth in the helical slot of the restraint cylinder. The oil is introduced into the adjuster body via a drilling from the cylinder block.

The backing plate, which incorporates a travel limiting stop, provides a suitable face along which the slipper head can work.

A small hole in the slipper head face provides lubrication.

FITTING WATER PUMP HOUSING

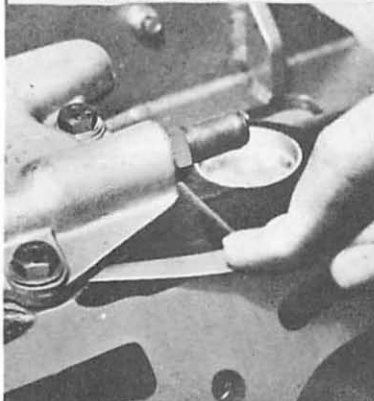

CLEARANCE, -0.010° - -0.020°
 $- .25\text{mm}$ - $.5\text{mm}$

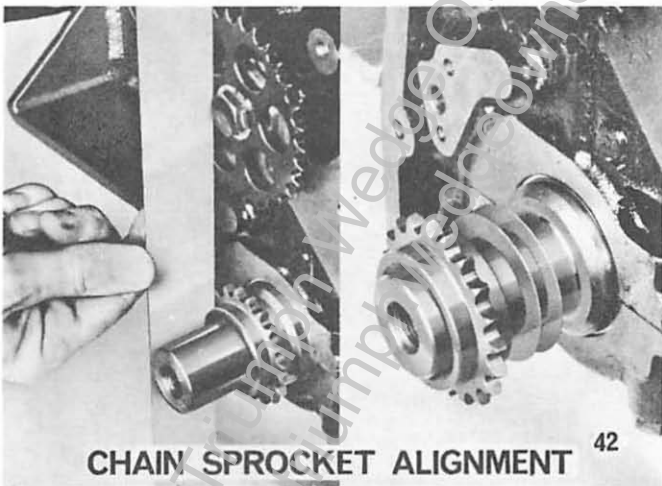
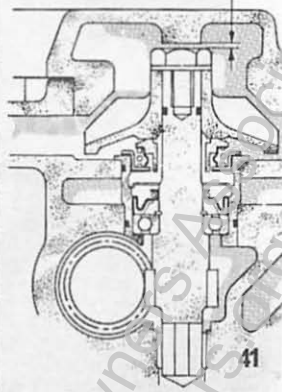

CHAIN SPROCKET ALIGNMENT

42

TIMING CHAIN TENSIONER ASSEMBLY



43

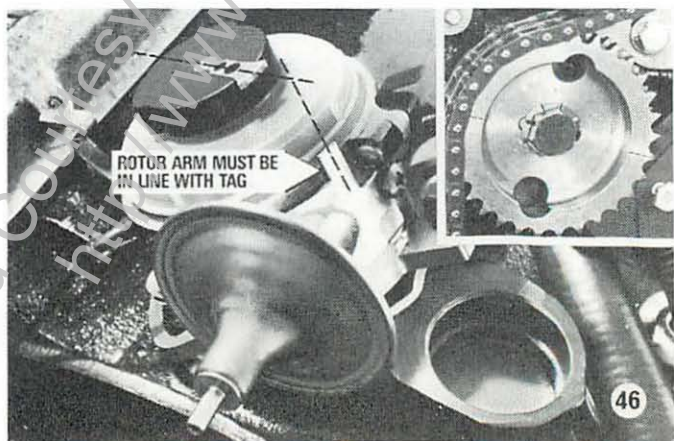
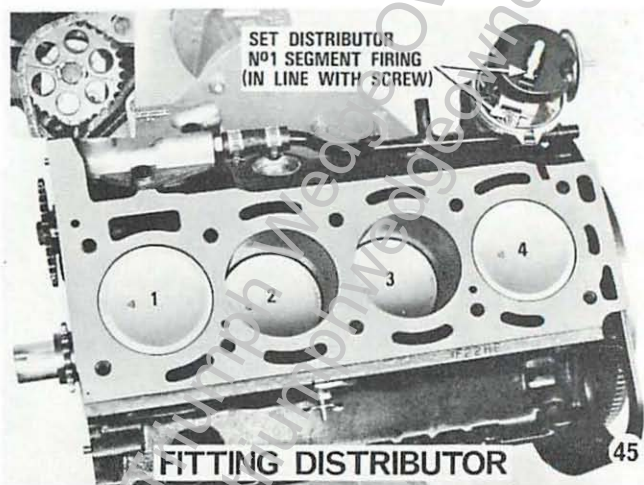
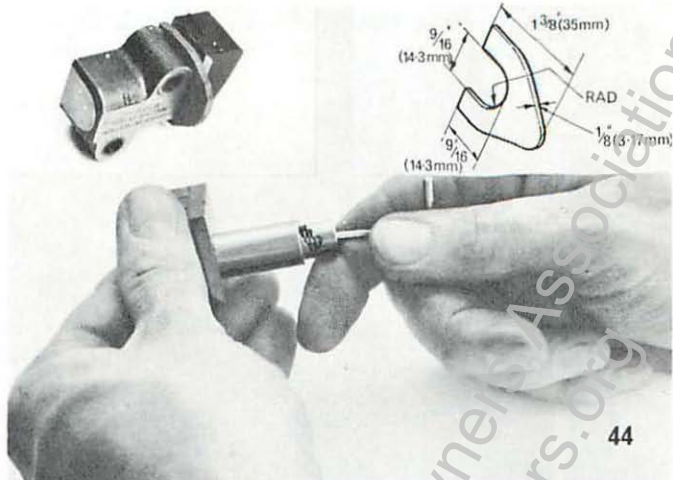

CHAIN TENSIONER ASSEMBLY

Assemble the plunger, restraint cylinder and spring. Insert an Allen key 0.125 in A/F (3.1 mm) into the restraint cylinder and turn key in a clockwise direction until the slipper head remains in the retracted position.

Make a cardboard template to the dimension shown in the illustration and place in position behind slipper head on plunger.

The cardboard template prevents accidental actuation of the spring when assembling the plunger to the tensioner body.

NOTE: DO NOT remove cardboard spacer until final chain adjustment takes place.

FRAME 45

FITTING THE DISTRIBUTOR - SLANT 4 ENGINE

Turn the idler shaft until the dowel, showing on the chain wheel, is on the left-hand side and the scribe line points approximately one tooth down from the horizontal position on the right as shown in the illustration.

Offer up the distributor to the cylinder block with the vacuum advance unit facing the rear of the engine. When the distributor is fitted correctly the rotor arm contact **MUST** be in line with the condenser securing screw. Failure to achieve this condition may be due to the distributor drive gear being one tooth out of alignment, in which case it will be necessary to withdraw distributor and refit correctly.

Ensure distributor cap retaining clips are held close to distributor body, as shown, to avoid trapping clips when refitting cylinder head.

FRAME 46

FITTING THE DISTRIBUTOR - 16 VALVE ENGINE

NOTE: The crankshaft must be at T.D.C. No. 1 cylinder firing and the dowel in the idler shaft gear wheel on the left-hand side with the scribe line pointing one tooth down from the horizontal position on the right as shown.

Fit the distributor mounting plate to the cylinder block with two bolts and spring washers. Offer up the distributor to the cylinder block, with the vacuum advance unit facing rearwards.

When the distributor is fitted correctly the rotor arm **MUST** be in line with the distributor cap locating tag as shown above. Failure to achieve this condition may be due to the distributor drive gear being one tooth out of alignment, in which case it will be necessary to withdraw the distributor and refit correctly. The distributor is secured by two bolts, two plain and two spring washers.

Ensure distributor cap retaining clips are held close to distributor body as shown, to avoid trapping clips when refitting cylinder head.

PART 5

FITTING THE CYLINDER HEAD- SLANT 4 ENGINE

NOTE: Crankshaft set No. 1 piston T.D.C. firing.

Place the timing chain on the camshaft chain wheel and fit chain and chain wheel to camshaft. Secure with two bolts and tab washer, tighten to 7 to 10 lbf ft (1.0 to 1.4 kgf m). Bend up tabs. Turn camshaft until timing marks align (see inset).

Fit two long studs to block in the position shown to facilitate refitting the cylinder head.

Ensure that the cylinder head and block faces are perfectly clean.

Place cylinder head gasket in position.

Offer up the cylinder head to the block and feed the timing chain through the aperture in the head gasket.

Screw the five long cylinder head studs into the top set of holes in the cylinder head (the studs screw into the cylinder block at an angle), fit washers and nuts.

Remove the two long studs used to fit the cylinder head and refit five bolts and washers.

Fully tighten the cylinder head nuts and bolts to 45 to 55 lbf ft (6.2 to 7.6 kgf m) in the sequence shown in Frame 5.

NOTE: DO NOT TURN CAMSHAFT OR CRANKSHAFT with the cylinder head fitted and the timing chain disconnected. The valves protrude below the face of the cylinder head and will foul the pistons.

FITTING THE CYLINDER HEAD-16 VALVE ENGINE

NOTE: Crankshaft set No. 1 piston firing T.D.C.

Turn the camshaft to line up the timing marks on the camshaft bearing cap (see inset).

Proceed as for Slant 4 engine.

NOTE: DO NOT TURN THE CAMSHAFT OR CRANKSHAFT with the cylinder head fitted and the timing chain disconnected. The valves protrude below the face of the cylinder head and will foul the pistons.

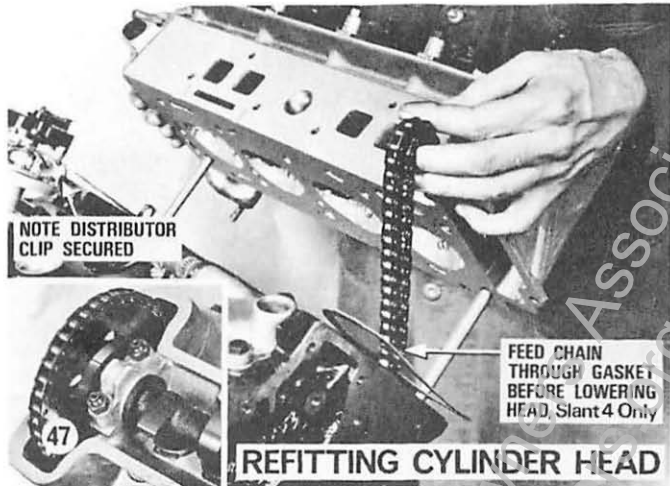

**NOTE DISTRIBUTOR
CLIP SECURED**

**FEED CHAIN
THROUGH GASKET
BEFORE LOWERING
HEAD, Slant 4 Only**

REFITTING CYLINDER HEAD

47

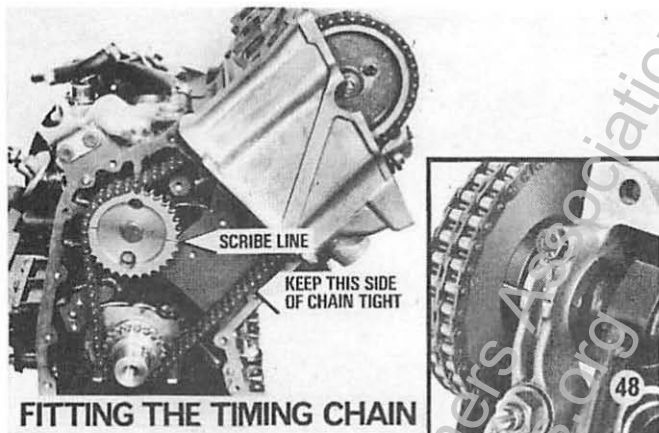

TIMING CHAIN GUIDES

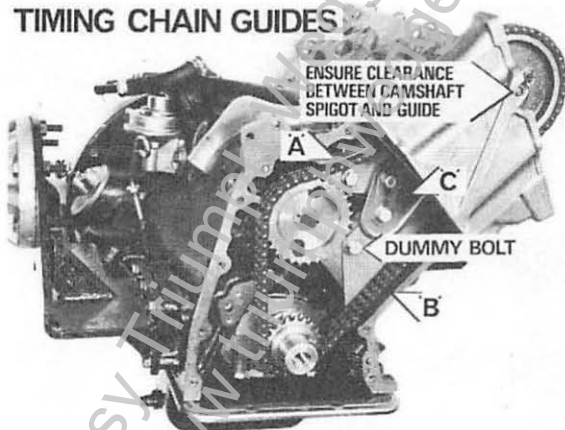

49

FITTING TIMING CHAIN-SLANT 4 ENGINE

Feed timing chain around crankshaft sprocket, keeping the chain as tight as possible on its longest side as shown in illustration.

Fit chain around idler shaft, taking care not to move shaft.

Having fitted the chain, check the position of the camshaft scribe mark and distributor to ensure they have not moved during assembly.

16 VALVE ENGINE

The procedure for fitting the timing chain on the 16 valve engine is basically the same as for the Slant 4 except for the following details.

Offer up the timing chain and camshaft timing gear to the camshaft and align the two securing holes.

Feed the chain around the crankshaft and idler sprockets.

Press the chain wheel spigot into the end of the camshaft.

Ensure that the longest side of the chain is taut.

Secure the camshaft chain wheel to the camshaft with two bolts and tab washers. **DO NOT TURN THE ENGINE** to tighten the other chainwheel bolt at this stage. Recheck position of scribe mark on idler shaft sprocket.

FRAME 49

TIMING CHAIN GUIDES

Slide the top chain guide 'A' into position and fit the securing bolt, spring and flat washer. **DO NOT** tighten.

Offer up the long chain guide 'B' to the bottom run of the timing chain and temporarily hold it in place with a suitable dummy bolt as shown.

Fit the camshaft chain wheel support bracket 'C'; the two bolts and washers securing the support bracket also secures the two chain guides.

Finally tighten the bottom bolt on the chain wheel support bracket, leaving the other chain guide loose.

NOTE: Ensure that there is clearance between the thread on the camshaft chain wheel spigot and the hole in the mounting bracket.

FITTING TIMING CHAIN TENSIONER

Using a cardboard spacer as shown in Frame 42, offer up the chain tensioner and travel limiting plate to the mounting points on the block and ensure the oil feed dowel is in position. Secure chain tensioner with two bolts and washers, then tighten to 6 to 9 lbf ft (0.8 to 1.2 kgf m).

Remove cardboard spacer from chain tensioner carefully to avoid actuating unit.

Insert 0.100 in (2.5 mm) shim between the tensioner head and body. Remove all slackness from the chain and tighten the chain guide adjustment bolt.

Tighten chain guide bolts to 15 to 20 lbf ft (2.1 to 2.8 kgf m).

Check that shim is a sliding fit—if not chain is too tight.

NOTE: Ensure there is clearance between the thread on the sprocket spigot and the hole in mounting bracket.

Remove 0.100 in (2.5 mm) shim.

Ensure chain is running on chain guide rubber.

Remove 'dummy' bolt from bottom hole of long chain guide.

16 VALVE ENGINE

Re-check the position of the scribe line on the idler gear. Turn the engine to enable the second camshaft gear securing bolt to be tightened. Knock up the tabs on the bolts. Return the engine to T.D.C. No. 1 cylinder firing.

FRAME 51

FRONT OIL SEAL

Press oil seal into the front timing cover with the lip of the seal facing inwards.

Using a straight-edge, check that the seal is flush with the outer face of the timing cover.

Lubricate the seal with S.A.E. 140 oil.

FRAME 52

FAN IDLER PULLEY

The fan idler pulley mounting and bearing is attached to the front cover by three bolts and spring washers.

It will be found convenient to fit the pulley mounting before securing the front timing cover to the cylinder block.

DO NOT DISMANTLE THE IDLER UNIT. The unit is balanced and requires no servicing.

Failure to observe these instructions may result in premature failure of the unit.

NOTE: Before fitting the idler pulley and bearing fit the centre bolt for the timing cover. Ensure the fibre washer is fitted between the plain washer and timing cover.

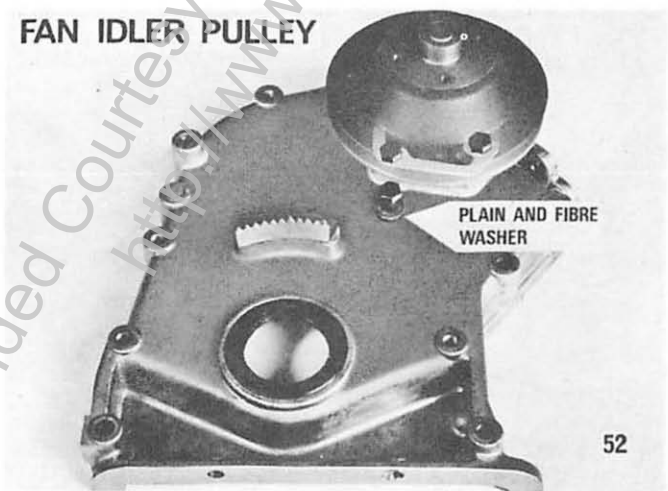
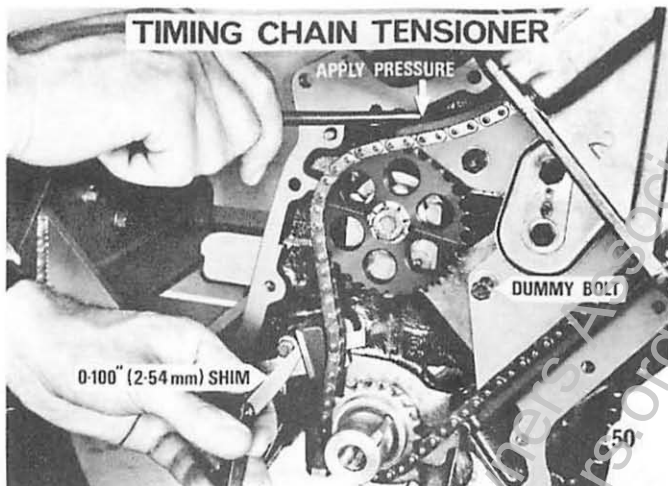

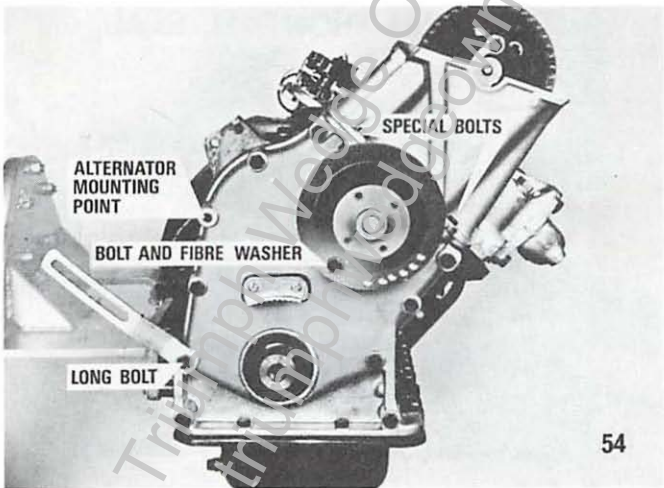
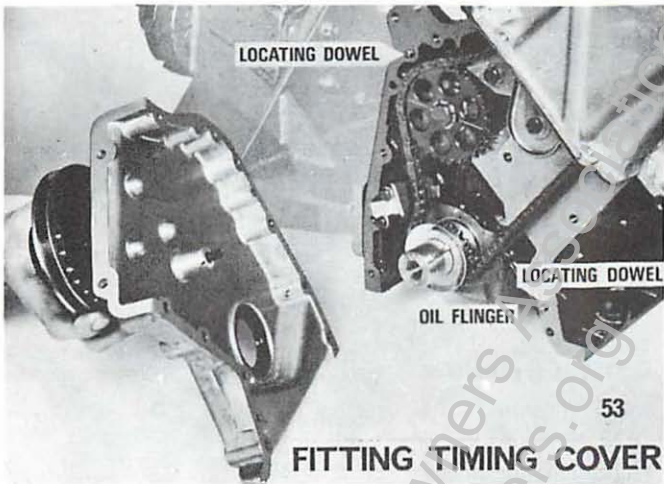

FITTING FRONT TIMING COVER

Fit the oil flinger to the nose of crankshaft, 'dished' side outwards.

Offer up front timing cover with seal and gaskets.

Care should be taken not to damage the oil seal on crankshaft Woodruff key and also that the cylinder head and sump gaskets are suitably protected.

FRAME 54

TIMING COVER BOLTS

Two dowels locate the front timing cover to the cylinder block.

The timing cover is secured by nine equal-length bolts and washers tightened to 15 to 20 lbf ft (2.0 to 2.8 kgf m). A longer bolt is used to secure the alternator adjustment strap as shown in the illustration.

Ensure a fibre washer is fitted between the plain washer and timing cover on the bolt indicated.

Secure timing cover to cylinder head using two special bolts, washers and nuts tightened to 15 to 20 lbf ft (2.1 to 2.8 kgf m).

The bottom of the timing cover is secured to the sump by two bolts nuts and washers.

Tighten all sump bolts.

FRAME 55

FITTING DAMPER ASSEMBLY

Oil the front oil seal before offering up the damper and pulley assembly to the front of the crankshaft.

Ensure damper engages correctly with key on nose of crankshaft and that oil seal has not been damaged.

Secure with special bolt and plain washer and tighten to 90 to 120 lbf ft (12.4 to 16.6 kgf m).

NOTE: Damper assembly may be removed using a universal puller.

FITTING SPARK PLUG TUBES- 16 VALVE ENGINE

As the sparking plugs are recessed deep into the cylinder head it has been necessary to fit tubes between the head and camshaft cover.

The sparking plug tubes have rubber seals at either end, and the seal with the large lip must be fitted uppermost, i.e. to butt against the camshaft cover.

No sealing compound is necessary to seal the tubes although a smear of rubber grease will facilitate fitting.

FRAME 57

IGNITION TIMING

The rotor arm moves in an anti-clockwise direction.

To set the ignition timing proceed as follows:

1. Rotate the engine and with the contact breaker on the peak of the cam lobe, adjust to 0.014 to 0.016 in (0.35 to 0.41 mm) gap in the normal way.
2. Rotate engine backwards for at least half a revolution and then rotate forwards until the timing mark on the damper is aligned with 11° B.T.D.C. on the scale (10° BTDC on 16 valve engines).

NOTE: ENGINE FIRING No. 1 CYLINDER.

3. Disconnect the distributor negative wire from the coil and connect a low wattage 12-volt lamp between the negative wire and the live terminal of the battery.
4. Rotate distributor body until contact breaker points start to open, i.e. test lamp goes out.
5. Tighten two distributor securing bolts.
6. Refit distributor cap and leads.
7. Refit sparking plugs—Champion N11Y (Slant 4 engines).

On 16 valve engines the sparking plugs are Champion BN 7Y, which **MUST** be tightened to 8 lbf ft (0.83 kgf m) as they are not fitted with plug washers. The plug spanner size is 10 mm.

NOTE: For adjustment of distributor contact breaker gap with engine in car refer to pages 75 and 76.

SPARKING PLUG TUBES



NOTE LARGE
LIP
UPPERMOST

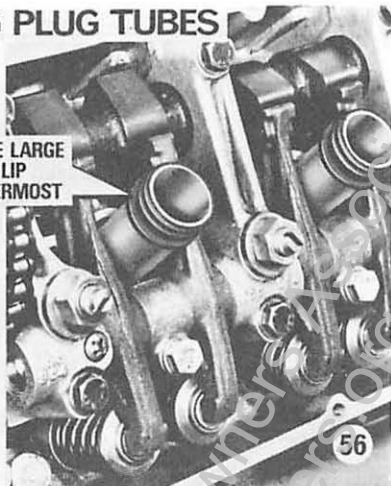

56

IGNITION TIMING

16 Valve Engine— 10°
Slant 4 Engine— 11°

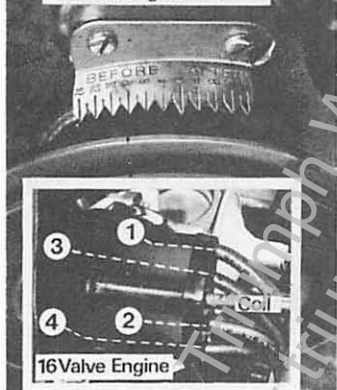

16 Valve Engine

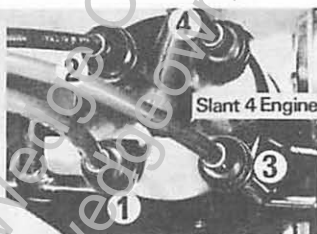

Slant 4 Engine

DIRECTION
OF ROTATION



57

CONTACT BREAKER POINTS GAP
0-014" - 0-016" (0-35 - 0-4 mm)

SLANT 4 INLET MANIFOLD REFITTING

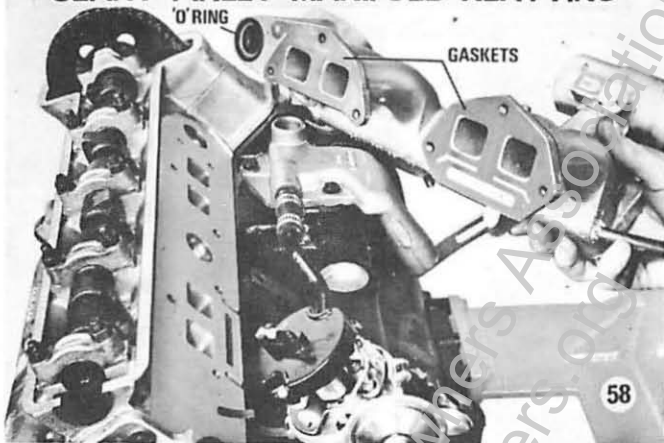

THERMOSTAT HOUSING AND WATER PUMP COVER SEAL

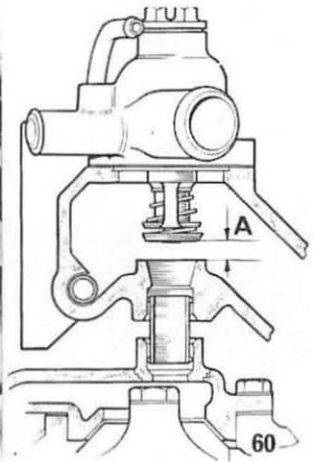

INLET MANIFOLD— SLANT 4 ENGINE

It will be found advantageous to fit the carburettors to the inlet manifold before offering up the manifold to the cylinder head.

The carburettors have been omitted from the illustration for reasons of clarity.

The inlet manifold is secured to the cylinder head with six bolts and washers tightened to 15 to 20 lbf ft (2.1 to 2.8 kgf m).

Two bolts are longer; these are used to secure the engine lifting bracket and the inlet manifold.

NOTE: The heater pipe is secured to the front bolt on the rear inlet manifold flange.

Two gaskets and a rubber 'O' ring seal the inlet manifold to the cylinder head.

It is recommended that rubber grease is used around the 'O' ring.

16 VALVE ENGINE

The inlet manifold is secured to the cylinder head by 10 bolts and washers tightened to 15 to 20 lbf ft (2.1 to 2.8 kgf m).

NOTE: There is a single-piece gasket fitted between the inlet manifold and cylinder head.

The inlet manifold, carburetter and throttle linkage may be fitted as an assembly.

FRAME 59

PART 6

THERMOSTAT AND HOUSING

The thermostat housing is integral with the inlet manifold.

The thermostat is held in position by the top cover secured with two bolts and washers and the assembly is sealed by a gasket.

Sealing the connecting water passage between the inlet manifold and the water pump housing is achieved by using a special seal as shown in the inset.

This **MUST** be fitted after the inlet manifold is bolted into position.

Using grease as a lubricant, press the seal through the hole in the base of the thermostat housing and into the water pump housing.

Replace the thermostat, gasket, top cover, with large outlet pipe facing forward and secure with two bolts.

The cooling system is of the NO LOSS type and is pressurized to 13 lb/in².

NOTE: It is important to use an ANTI-FREEZE specially made for use with aluminium components.

FRAME 60

It is most important that the correct type of thermostat is fitted to the engine, otherwise overheating will take place.

When the engine is started from cold, the by-pass passage between the water pump cover and the inlet manifold is open and the water flow to the radiator is restricted.

As the engine attains normal working temperature the by-pass passage, at 'A', is closed by the action of the thermostat and the water re-routed to flow through the radiator.

PART 7**STROMBERG CARBURETTER 150.CDS(E)V**

The Stromberg carburetter as illustrated above was fitted to early production Slant 4 engines. Later engines are fitted with SU HS4 carburetters. See pages 56-67 for description and tuning details.

The Stromberg 150 CDS(E)V carburetters have the following features:

Air/fuel mixture is adjusted by special tools inserted through the top of the carburetter.

The needle, which is spring-loaded, is biased towards the air cleaner elbow.

FRAME 62

FLOAT-CHAMBER VENT VALVE

The carburetters have an additional valve which allows fuel vapour from the float-chamber to be vented to atmosphere when the engine is idling or stationary.

As soon as the engine is started and the throttle actuated, the valve opens allowing the vapour to be vented through the air cleaner and consumed by the engine.

This eliminates the hot-start problem when excess vapour collects in the air cleaner and inlet manifold.

The valve is set during manufacture and no adjustment is necessary during the service life of the carburetter.

FRAME 63

FAST IDLE ADJUSTMENT

(ENGINE AT NORMAL RUNNING TEMPERATURE)

Before making any adjustments, ensure the choke knob is fully in the fascia and the choke cam is against the stop on the carburetter.

Stop the engine and place a piece of $\frac{5}{16}$ in (7.9 mm) diameter bar between the fast idle cam and the stop as shown in the illustration.

Adjust the fast idle screw until the head of the screw just touches the cam, then tighten the locknut and remove the setting bar.

Pull out choke to fast idle position, start engine and note engine speed which should be 1,400 to 1,600 rev/min.

If engine speed is below the figure given, it is permissible to adjust the fast idle screw to obtain a satisfactory engine speed.

Tighten fast idle screw locknut.

STROMBERG 150 CDS(E)V CARBURETTOR

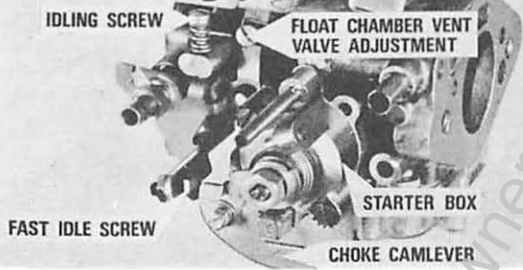

FLOAT CHAMBER VENT VALVE

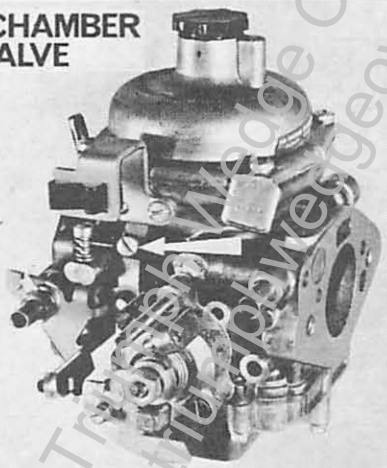

FAST IDLE ADJUSTMENT

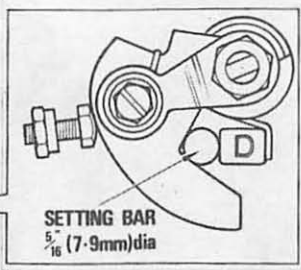
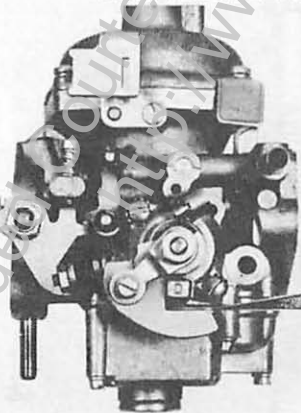

63

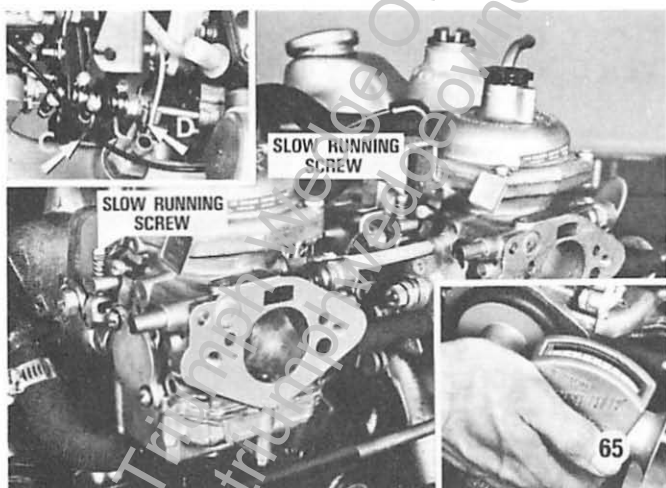
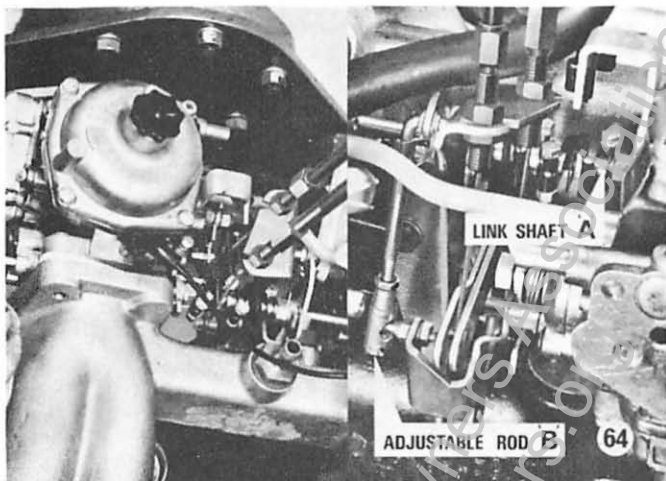

**CARBURETOR
JET ADJUSTING
TOOLS IN
POSITION**

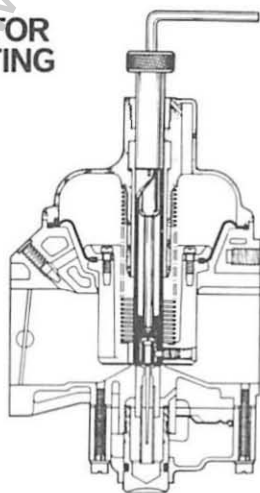

FRAME 64

Slacken clamp securing link shaft 'A' between the two carburetters and disconnect the adjustable rod 'B' from the bell-crank.

FRAME 65

Using air balance equipment as shown, check for equal breathing on both carburetters. Adjust the slow running screws until equal breathing and an engine idling speed of 700 to 750 rev/min is obtained.

Re-connect the link shaft 'A' between the carburetters. Hold bell-crank arm against stop 'C'.

Rotate ball end of adjustable rod to give approximately 0.010 in (0.25 mm) clearance at point 'D' and to take up slackness due to tolerances in linkage.

Refit ball end to bell-crank arm and tighten locknut.

Adjust throttle cable to eliminate slackness.

FRAME 66

CARBURETTER NEEDLE ADJUSTMENT THROUGH THE TOP COVER

Provision is made to adjust the air/fuel ratio by moving the carburetter needle using the special tools shown above.

CARBURETTER MIXTURE ADJUSTMENT

NOTE: In certain European countries with regulations governing EXHAUST EMISSION CONTROL, it is ESSENTIAL that the carburetters are adjusted in conjunction with a CO Meter to ensure legal requirements are not exceeded. Idle CO Level, engine warm 2 to 4½%. Equivalent air/fuel ratio at idle (approx.) 13.8 : 1 to 12.8 : 1.

Check the mixture on each carburetter by lifting the air valve $\frac{1}{32}$ in (0.8 mm) and noting engine reaction.

- Increase in speed indicates rich mixture.
- Decrease in speed and engine stall indicates lean mixture.
- Slight increase in engine speed, then a fall-off, indicates an ideal economical mixture.

To adjust the air/fuel mixture, unscrew the damper from the carburetter top cover and, to prevent loss of damper oil, slowly insert tool 'A' until the lugs engage with the slots in the air valve tube. Insert tool 'B' through the centre of 'A', which automatically centres the hexagonal end of tool 'B' to engage with the screw adjustment at the bottom of the air valve tube.

To richen the mixture, hold tool 'A' to prevent the air valve turning and rotate tool 'B' in a clockwise direction by increments of a quarter of a turn.

To weaken the mixture, turn tool 'B' in an anti-clockwise direction.

There is approximately one full turn in each direction.

Remove the special tools, check carburetter air valve damper oil level, and replace damper.

To finally check mixture replace air cleaner and elbows, reset idling if necessary to 700 to 750 rev/min and blip throttle.

If engine stalls, richen mixture by a quarter turn on each carburetter.

SU CARBURETTER TYPE HS4 AND HS6 —SERVICING AND TUNING

The Slant 4 engines are fitted with twin HS4, 1½ in (38.1 mm) SU carburetters and the 16 valve engines with twin HS6 1¾ in (44.4 mm) carburetters. Both engines are fitted with similar throttle linkages.

The main features of the HS4 and HS6 SU carburetters are shown in the above illustration and are as follows:

- Jet adjusting nut.
- Jet locking nut.
- Piston/suction chamber.
- Fast idle screw.
- Throttle adjusting screw.
- Piston lifting pin.

CARBURETTOR MIXTURE ADJUSTMENT

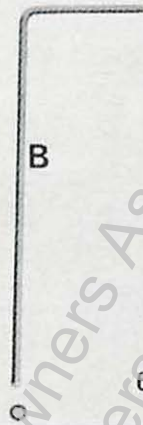

67

SU HS6 CARBURETTOR

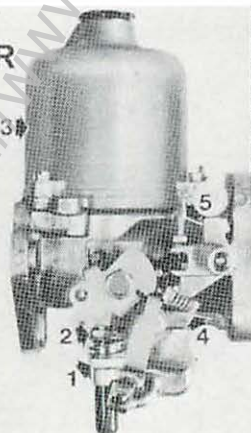

68

CHECKING FLOAT HEIGHT

$\frac{1}{8}$ "
(3.1mm)

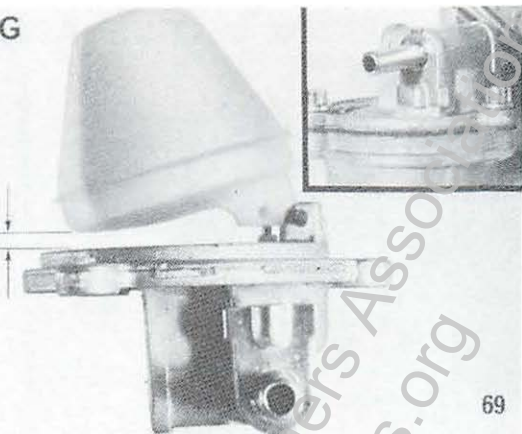

CARBURETTER NEEDLE COMPONENTS



CARBURETTER NEEDLE FITTING

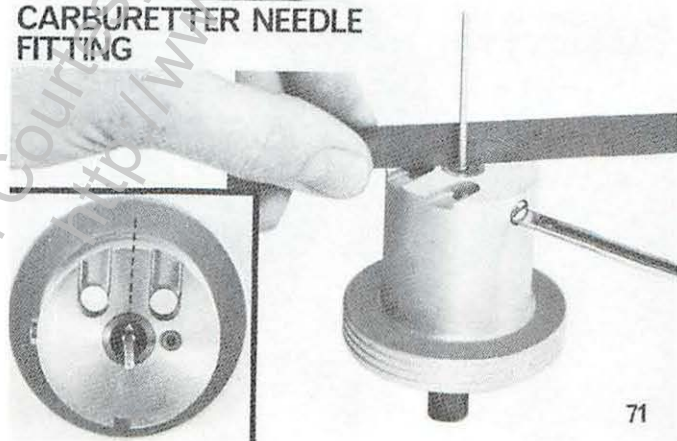

CHECKING FLOAT HEIGHT

All float level heights are checked at the factory to $\frac{1}{8}$ in (3.1 mm) as shown.

The floats are non-adjustable. If the float height is incorrect, the needle valve should be checked for damage and correct operation.

When refitting the float-chamber lid ensure that the petrol inlet pipe is facing the correct way (see inset) and that the gasket is in good condition.

FRAME 70

NEEDLE IDENTIFICATION

The carburettor needle identification letters are stamped on the shank of the needle as shown.

When fitted correctly, the needle is automatically biased towards the air cleaner side of the carburettor by a small step on one side of the needle holder.

MODEL	Needle code letters
Dolomite	ABK
Sprint	BBT (early cars) BCM (later cars)

FRAME 71

NEEDLE FITTING

NOTE: Before assembly, examine the needle holder and clamping screw for damage or scoring; replace as necessary.

Place the needle and needle holder together with the small spring into the piston.

NOTE: A 'V' is stamped on the bottom of the needle holder and the 'V' should be facing midway between the two transfer holes.

Press the needle holder into the piston, against the spring pressure, until the holder is flush with the piston base, and tighten the needle clamping screw.

FRAME 72

JET ASSEMBLY

The jet assembly components are shown in the illustration above and are as follows:

- A. Jet head securing screw to control linkage.
- B. Fuel feed pipe union sealing washer.
- C. Jet.
- D. Locking spring.
- E. Jet adjustment nut.
- F. Jet bearing and lock nut.

It is unnecessary to centre the jet on this type of carburetter.

FRAME 73

Offer up the jet bearing and lock nut 'F' to the carburetter body. Tighten the lock nut.

Place the locking spring 'D' onto the jet bearing and screw the jet adjusting nut 'E' onto the jet bearing.

Replace the jet assembly 'C' as described in Frame 74.

FRAME 74

JET ASSEMBLY

Before replacing the fuel feed pipe into the float-chamber fit the rubber sealing washer over the end of the plastic pipe so that at least $\frac{3}{16}$ in (4.8 mm) of pipe protrudes.

Replace the jet and fuel pipe. Connect the jet head screw to the control lever.

Screw the jet adjusting nut to the fully up position, then back off 12 flats (two complete turns) to give a nominal setting before refitting the carburetter to the engine.

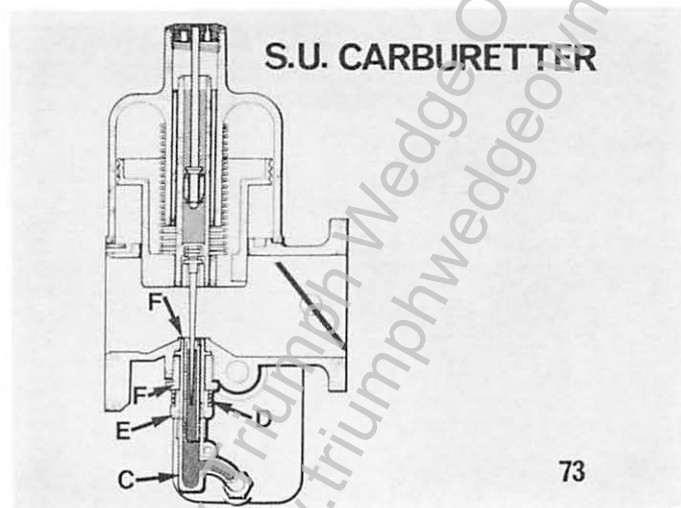
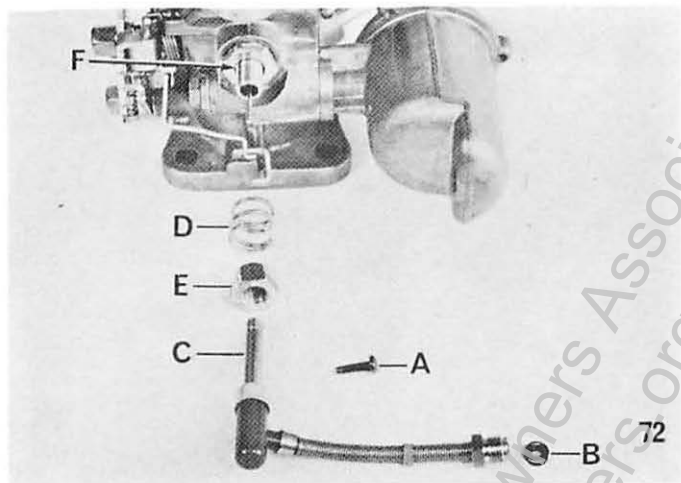

74

SEALING WASHER

SUCTION CHAMBER AND PISTON



SUCTION CHAMBER DROP TEST

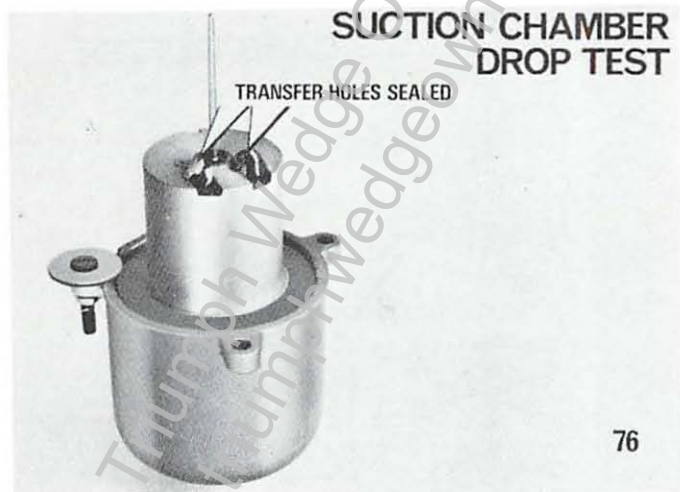

SUCTION CHAMBER AND PISTON

If after use the carburetter piston becomes slow to return to the bridge of the carburetter, the piston/suction chamber unit may be removed and cleaned with a solvent. Abrasives must never be used. Drying should be done using a jet of compressed air.

NOTE: The piston rod should not be handled as moisture from the fingers may cause corrosion.

Lightly oil the piston rod only before reassembly.

SUCTION CHAMBER DROP TEST

With the piston assembled in the suction chamber as shown, invert the assembly, allowing the suction chamber to fall away from the piston.

NOTE: The transfer holes must be sealed for this test.

The time taken for the total movement should be 5 to 7 seconds. If this time is exceeded, check the piston and chamber for cleanliness or mechanical damage.

Renew the assembly if the time taken is still not within limits.

The washer shown prevents the components separating during the test.

TUNING THE CARBURETTERS

NOTE: Before starting carburetter tuning check the level of oil in the carburetter piston damper. Top up with the recommended grade of engine oil until the level is $\frac{1}{2}$ in (13 mm) above the top of the piston rod.

Warm up the engine to normal running temperature, stop the engine and remove the air cleaner. Slacken both clamping bolts 'A' on the throttle spindle interconnections, also clamping bolts 'B' on the jet control interconnection spindle.

Ensure that both fast idle screws are clear of their respective cams. By slackening off the interconnecting clamps each carburetter may be adjusted independently.

Unscrew the slow running screw 'C' on each carburetter and ensure that the throttles are fully closed.

Open both throttles $1\frac{1}{2}$ turns of the slow running screw. Start the engine.

(Continued on next frame)

FRAME 78

Using a Synchro check, or similar airflow meter, adjust the slow running screws until the air flow through the carburetters is balanced and the engine speed is between 650 and 800 rev/min.

**UNITED KINGDOM EXHAUST EMISSION REQUIREMENTS
COMMENCING SEPTEMBER 1973**

As from September 1973, new laws governing exhaust emissions in the United Kingdom will come into effect.

One of the requirements is that CO levels at idling should be within 4½%. The amount of CO emitted can be most accurately checked using non-dispersive infra-red CO measuring equipment.

Check for correct mixture strength on each carburetter by lifting the pin on the body of the carburetter $\frac{1}{32}$ in (0.8 mm) after free movement has been taken up.

RICH MIXTURE rev/min increases considerably.

CORRECT MIXTURE rev/min increases very slightly.

WEAK MIXTURE rev/min immediately decreases.

TO WEAKEN the mixture screw the jet adjusting nut up, and to **RICHEN** the mixture screw the nut down, until the fastest idling speed consistent with even running is achieved.

(Continued on next frame)

TUNING THE CARBURETTORS

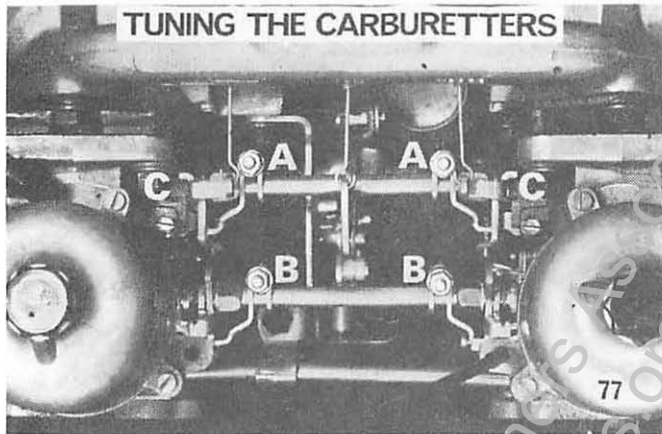

BALANCING CARBURETTORS WITH AN AIRFLOW METER

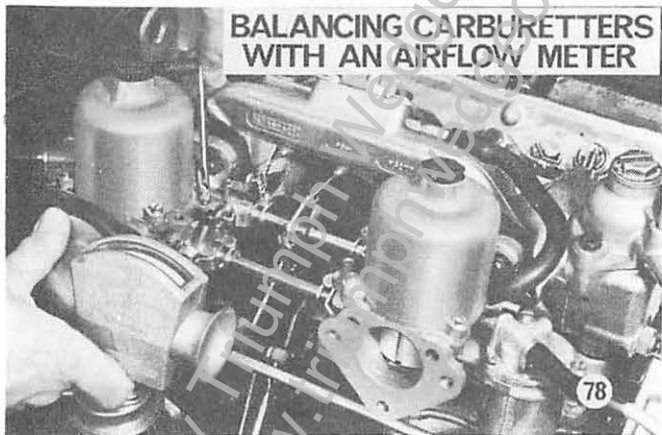

Provided Courtesy of
<http://www.FordMustangV8.com>

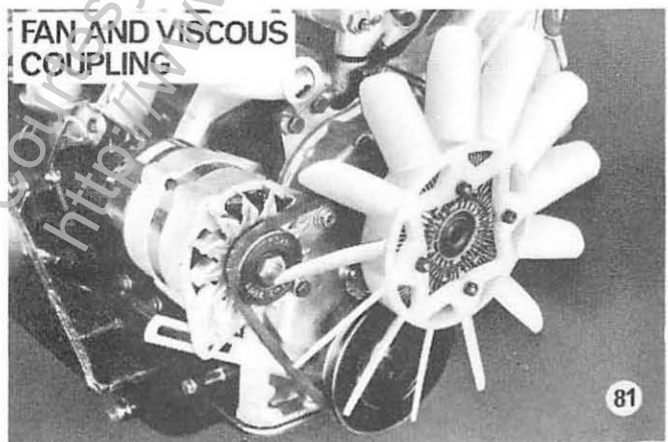
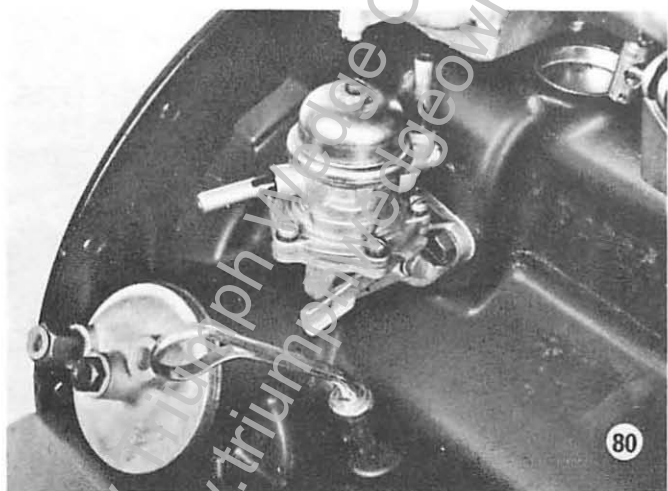
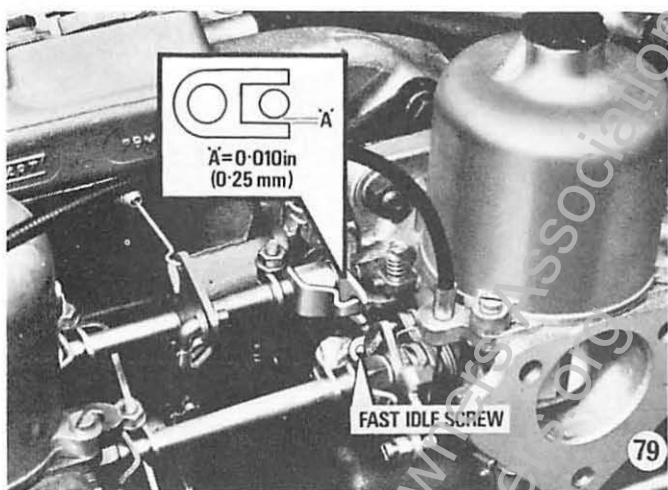

FRAME 79

Re-adjust the throttle slow running screws as necessary to give the correct idling speed.

Stop the engine.

Set the throttle interconnecting clamping levers so that there is 0.010 in (0.25 mm) gap 'A' as shown in the illustration, then tighten the clamping bolts.

The mixture control wire should have approximately $\frac{1}{16}$ in (1.6 mm) movement before the linkage is moved.

Tighten both mixture control interconnection clamping levers.

Pull the mixture control knob until the linkage is about to move the carburetter jets, and adjust the fast idle screws to give an engine speed of approximately 1,100 to 1,300 rev/min when hot.

Refit the air cleaner.

FRAME 80

PETROL PUMP

The petrol pump is mounted on the side of the cylinder block and is secured by two bolts and washers.

The AC diaphragm pump is operated by a lever running on an eccentric cam on the idler shaft.

Petrol is filtered by a gauze incorporated in the top of the pump body. The delivery pressure is 2.5 to 3.5 lb/in² (0.17 to 0.25 kg/cm²).

FRAME 81

PART 8

FAN VISCIOUS COUPLING

A viscous coupling is used to drive a high-capacity cooling fan so that it is fully effective at low and high engine speeds while almost halving the power loss at high revolutions.

ALTERNATOR

The alternator fitted to the Slant 4 engines is a Lucas 15ACR and a 17ACR is fitted to the 16 valve engines.

The alternator is secured to the front timing cover by a single long bolt, two plain washers, a spacer and self-locking nut.

The bottom mounting lug on the alternator is attached to the adjustment bracket.

FAN ASSEMBLY

The plastic fan is attached to the idler pulley by four bolts and spring washers.

DRIVE BELT ADJUSTMENT

Slacken alternator securing bolts and apply tension to the belt until there is $\frac{1}{2}$ in (12.7 mm) movement at the mid-point on the longest length of drive belt.

Maintaining the alternator in this position, tighten securing bolts.

PART 9**DISTRIBUTOR-SLANT 4 ENGINE**

To adjust the contact points on the AC-Delco distributor it will be advantageous to remove the unit from the cylinder block.

Before removal, turn engine to T.D.C. No. 1 firing to facilitate refitting.

Remove distributor cap and h.t. leads.

Remove the two screws and washers securing the rotor arm.

NOTE: The rotor arm will only fit one way.

Slacken the two adjustment screws shown in the illustration.

Turn the distributor until the contact breaker arm is on the peak of the cam lobe. By moving the base plate in the appropriate direction by means of the slots, set the points gap to 0.014 to 0.016 in (0.35 to 0.4 mm) and tighten screws. The distributor rotor arm rotates in an anti-clockwise direction.

When refitting distributor to block, turn rotor arm until it is pointing to the screw on the body of the distributor, see inset of illustration, i.e. No. 1 segment.
(Continued on next frame)

FRAME 83

Slide distributor into position in cylinder block and ensure distributor shaft engages with oil pump drive.

With the distributor in the correct position, the securing bolt holes in the block are mid-way in the flange holes of the distributor.

NOTE: If oil pump drive shaft was removed with distributor, great care must be exercised when replacing the shaft as it is possible to drop it into the sump.

If engine is removed from car, it is easier to refit distributor then feed the drive shaft into position when refitting oil pump.

DISTRIBUTOR-16 VALVE ENGINE

A new type of Lucas distributor is fitted to the 16-valve engine; it is the 45D.

The new distributor will give extra performance and efficiency.

A plastic cover is fitted under the rotor arm to prevent 'flash over' between the H.T. and the base plate.

It is not necessary to remove the distributor to set the contact breaker points.

The points are adjusted in the normal way, with the contact breaker arm on the peak of the cam lobe.

SLANT 4 ENGINE DISTRIBUTOR

POINTS GAP
0-014"-0-016"
(0-35-0-4mm)

CONTACT BREAKER SECURING SCREWS

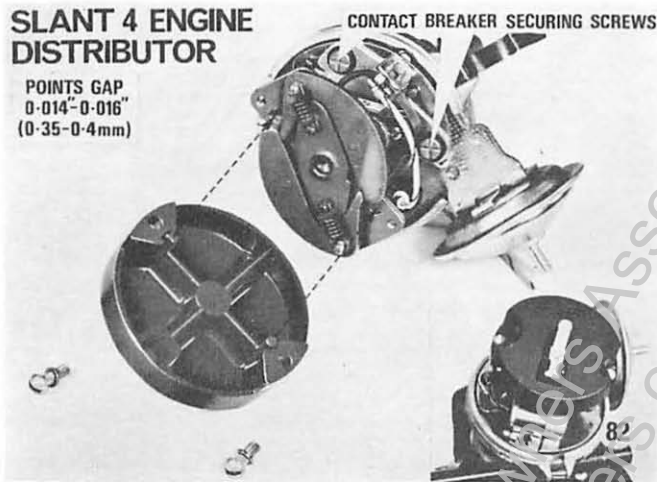

16 VALVE ENGINE DISTRIBUTOR

POINTS GAP
0-014"-0-016"
(0-35 - 0-4mm)

CONTACT BREAKER SECURING SCREW

CONTACT BREAKER

ROTOR ARM

PLASTIC SHIELD

83

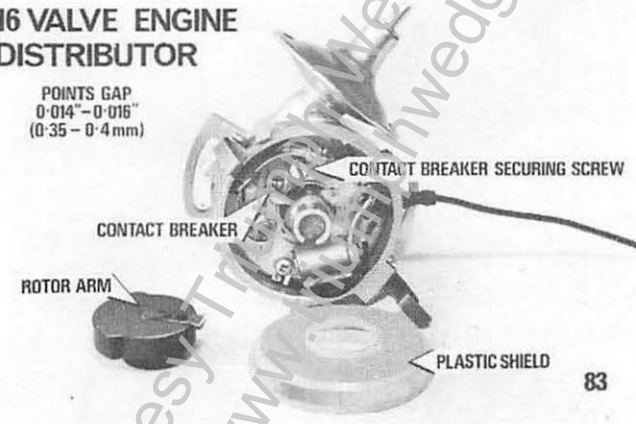

Provided Courtesy of <http://www.TruckWedgeOwnersAssociation.org>

EXHAUST MANIFOLD

A. 16-20 lb. ft. (2.2-3.0 kg. m.)
B. 26-34 lb. ft. (3.6-4.7 kg. m.)

SLANT 4 ENGINE

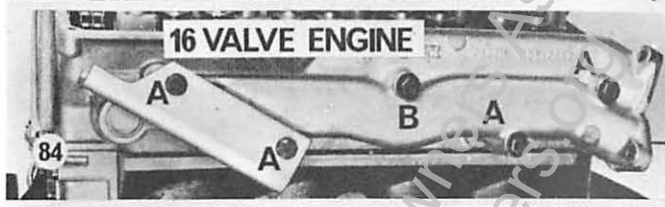

WATER PUMP EXTRACTOR

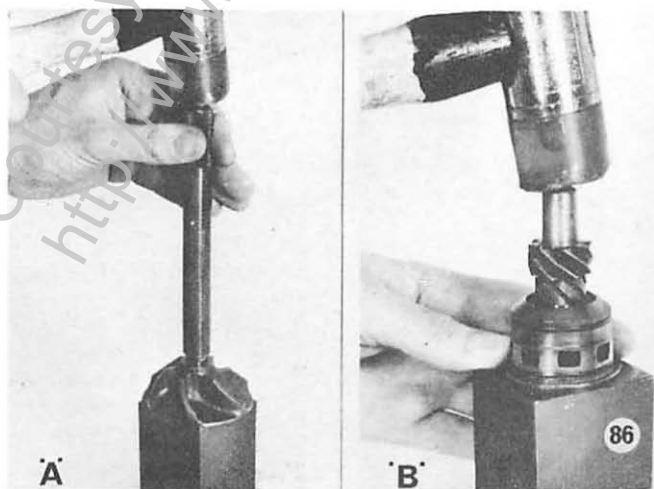

PART 10**EXHAUST MANIFOLDS-SLANT 4 ENGINE**

The exhaust manifolds are secured to the cylinder heads by seven bolts and spring washers.

There are no gaskets fitted between the manifold and head.

The outer four bolts 'A' should be tightened to 16 to 22 lbf ft (2.2 to 3.0 kgf m).

The inner three bolts 'B' should be tightened to 26 to 34 lbf ft (3.6 to 4.7 kgf m).

EXHAUST MANIFOLD-16 VALVE ENGINE

The exhaust manifold is secured to the cylinder head by five bolts and washers.

Two of the bolts are also used to secure an engine stabilizer bracket to the manifold.

There are no gaskets fitted between the manifold and head.

The four outer bolts 'A' should be tightened to 16 to 22 lbf ft (2.2 to 3.0 kgf m).

The inner bolt 'B' should be tightened to 26 to 34 lbf ft (3.6 to 4.7 kgf m).

PART 11**WATER PUMP REMOVAL**

Apply a socket spanner to the bolt head, which has a left-hand thread, and gently rock in a clockwise direction with the idler shaft held stationary. If complete assembly does not disengage itself from the cylinder block due to tightness, the bolt securing the impeller will unscrew. The special adaptor, part number S4235A/6 should be screwed into the water pump shaft and, by using an impact hammer part number S4235A (equivalent No. 3072), the pump assembly is withdrawn from the block.

NOTE: In certain circumstances the body of the water pump may be left in the block although the impeller, shaft bearing, etc., has been removed. The housing can be removed from the block using a Triumph 1300 gearbox tool S4235A-8.

WATER PUMP DISMANTLING AND RECONDITIONING

Remove the left-hand thread bolt and washer securing the impeller to the shaft.

Place the water pump assembly into the large hole of the dismantling tool No. 348/1 and, using tool No. 348/6, drift out the water pump shaft from the impeller as shown in illustration 'A'.

Using small hole in tool No. 348/1, place pump assembly in position as shown in 'B'.

Drift pump shaft from housing.

FRAME 87

Remove the rubber 'O' ring, graphite seal, water flinger, oil seal and circlip from the shaft.

Using the small hole in tool No. 348/7, place the shaft and bearing into position as shown.

Drift the shaft through the bearing and collect shaft, bearing and oil flinger.

FRAME 88

When reassembling water pump, always fit new seals and bearing.

Refit oil flinger, dish face towards drive gear shaft.

Slide bearing into position on shaft, place shaft into small hole in tool No. 348/7 as shown in 'A', and drift bearing into position, care being taken to centralize oil flinger.

Fit circlip onto shaft.

Place water pump body into small hole of tool No. 348/1. Place shaft and bearing gear downwards into pump body.

Using tool No. 348/2, drift bearing and shaft into position in body.

Replace the oil seal, spring uppermost, water flinger flange downwards, and tap gently into position using tool No. S348/2 in conjunction with tool No. S348/4 as shown in inset of 'B'.

NOTE: If unnecessary force is used, water flinger will spread and foul pump body.

FRAME 89

Refit graphite seal, marking face downwards.

Refit 'O' ring to shaft.

Place impeller into position on shaft and, using a suitable press, push impeller onto shaft until face of impeller is flush with shaft.

Refit washer and left-hand threaded bolt and tighten to 16–18 lbf ft (2.2 to 2.5 kgf m).

Refit two rubber 'O' rings to water pump body.

NOTE: Before replacing water pump assembly, examine bush in cylinder block for deterioration and replace as necessary.

WATER PUMP - DISMANTLING

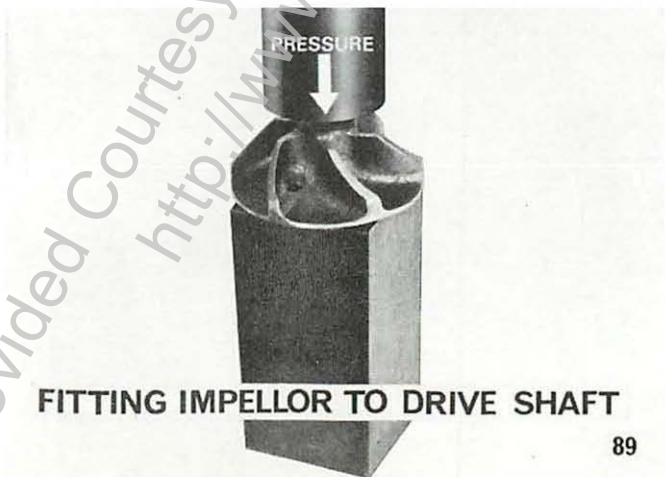
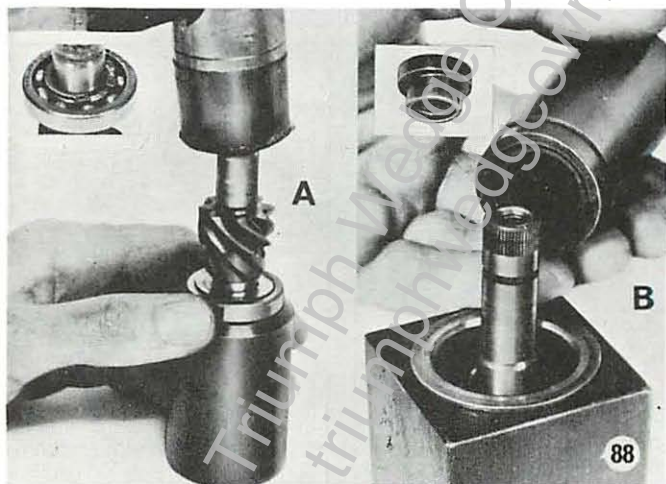
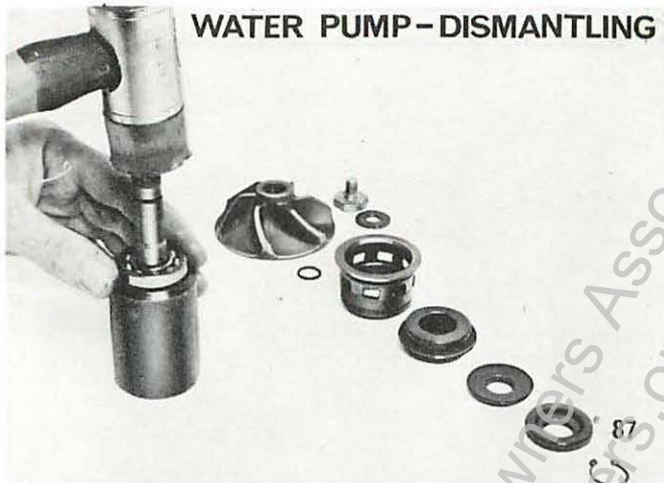

FITTING IMPELLOR TO DRIVE SHAFT

Provided Courtesy Triumph Wedge Owners Association
<http://www.triumphwedgeowners.org>

TORQUE SETTINGS

Chain wheel to camshaft	7-10 lbf.ft (0.9-1.3 kgfm)
Cylinder head studs and bolts	45-55 lbf.ft (6.2-7.6 kgfm)
Camshaft bearing cap bolts and nuts	12-16 lbf.ft (1.6-2.2 kgfm)
Oil pump to block	15-20 lbf.ft (2.0-2.8 kgfm)
Oil transfer housing to block	26-32 lbf.ft (3.6-4.4 kgfm)
Main bearing cap bolts	50-65 lbf.ft (6.9-8.9 kgfm)
Big end bearing cap nuts	40-45 lbf.ft (5.5-6.2 kgfm)
Rear oil seal	6-9 lbf.ft (0.8-1.2 kgfm)
Sump bolts	15-20 lbf.ft (2.1-2.8 kgfm)
Rear engine plate	15-20 lbf.ft (2.1-2.8 kgfm)
Flywheel bolts	40-45 lbf.ft (5.5-6.2 kgfm)
Idler shaft chain wheel bolt	30-38 lbf.ft (4.1-5.3 kgfm)
Idler shaft keeper plate screws	16-22 lbf.ft (2.2-3.0 kgfm)
Water pump housing to cylinder block bolts	15-20 lbf.ft (2.1-2.8 kgfm)
Timing chain tensioner bolts	6-9 lbf.ft (0.8-1.2 kgfm)
Timing chain guide bolts	15-20 lbf.ft (2.1-2.8 kgfm)
Timing cover bolts	15-20 lbf.ft (2.1-2.8 kgfm)
Timing cover to cylinder head bolts	15-20 lbf.ft (2.1-2.8 kgfm)
Damper assembly bolt	90-120 lbf.ft (12.4-16.6 kgfm)
Sparking plugs (Slant 4)	14-20 lbf.ft (1.9-2.8 kgfm)
Sparking plugs (16 valve 10 mm)	8 lbf.ft (0.83 kgfm)
Inlet manifold bolts	15-20 lbf.ft (2.1-2.8 kgfm)
Exhaust manifold outer bolts	16-22 lbf.ft (2.2-3.0 kgfm)
inner bolts	26-34 lbf.ft (3.6-4.7 kgfm)
Water pump impeller	15-18 lbf.ft (2.2-2.5 kgfm)
<i>Ignition Timing</i>	
Slant 4 engine	11° BTDC
16 valve engine	10° BTDC

Provided Courtesy Triumph Wedge Owners Association
<http://www.triumphwedgeowners.org>

Provided Courtesy Triumph Wedge Owners Association
<http://www.triumphwedgeowners.org>

Provided Courtesy Triumph Wedge Owners Association
<http://www.triumphwedgeowners.org>